

VAPOUR ADSORPTION REFRIGERATION : WORKING AND DESIGN

Merai Hastak¹ Preyas Patel² Shashwat Rajput³ Krunal Parikh⁴

^{1,2,3}Under Graduate Student, Indus University, Gujarat, India

⁴Professor, Department of Mechanical Engineering, Indus University, Gujarat, India

Abstract: Vapour adsorption refrigeration works on the principle of adsorption and Desorption. Adsorption and Desorption are surface phenomenon. Generally, adsorbate is adsorbed on the surface of Adsorbent, this process can be reverted by applying heat to the adsorbent. There are many adsorbate such as Methanol, Water, Ammonia and adsorbent such as activated carbon, activated carbon fiber, Silica-gel, Zeolite. The pair of adsorbent and adsorbate is called working pair. Different kind of working pair gives different results. Literature review suggests that around 0.25 to 0.5 coefficient of performance (COP) can be achieved. It has relatively low COP but it has advantage that it runs on low grade energy such as heat waste, solar energy, etc. This article include working cycle, design of components and calculation of Vapour Adsorption Refrigeration cycle.

Keywords: Vapour adsorption refrigeration, Design of adsorber bed, low grade energy, use of waste heat, Refrigeration and Air Conditioning

1. INTRODUCTION

Refrigeration and Air Conditioning (R&AC) is one of the growing field. Currently, Vapor Compression Refrigeration (VCR) is most preferred for commercial and industrial application. The requirement of Vapour Adsorption refrigeration system came because of the disadvantages of commercial and industrial refrigeration systems. Refrigerants used in this systems are hydro carbons. Which cause great damage to ozone layer, as found in 1985. Therefore, adsorption refrigeration system can be the alternative of current refrigeration system due to its operating and eco-friendly nature.[1] It does not have any moving parts. Adsorption refrigeration can be used in automobile and ice making. Generally, 10% of the engine power is used in cooling the cabin. In case of heavy vehicles around 20% power is used. It can also serve the purpose of cooling in industry[4]. It is found that adsorption system is sufficient to produce ice efficiently. It can produce ice of 10-15 kg in each cycle [5]. The only disadvantage of this system is COP. COP of this system varies from 0.2 to 0.5, it is highly depends on working pairs. There are different working pairs such as AC-NH₃, AC-methanol, Silica gel-water, AC+CaCl₂-NH₃, Zeolite-water, etc. Here, cooling is achieved by heat transfer so design of the system also plays role [6]. This system has high potential and can serve energy conversion requirements but it needs research in adsorber material [7]. There are some attempt to increase COP of system by integrated with a compound parabolic concentrator [8]. Therefore, best performance can be achieved by proper designing of component and working pair.

2. WORKING OF CYCLE

Above review shows that Vapour Adsorption Refrigeration cycle has good potential.

Cycle consists following components.

- 1) Water tank : There are two water tanks. One contain hot water (>60° C) and other contain cold water (< 20° C). Purpose is to charge and discharge adsorbate from adsorbent.
- 2) Adsorber bed : Adsorber bed is the key component in the system. It is one type of heat exchanger which contain adsorbent in it. Inside the tube hot or cold water is supplied depending upon the adsorption and desorption process and refrigerant flows in shell.

- 3) Evaporator : Evaporator consist coils in which liquid-vapour refrigerant is converted into vapour refrigerant at low pressure and temperature.
- 4) Condenser : Condenser consist coils in which vapour refrigerant is converted into liquid refrigerant at high temperature and pressure. Superheated vapour is cooled to saturation temperature and then it is condensed to a saturated liquid.
- 5) Expansion Valve : Expansion valve allows the liquid refrigerant to pass at controlled rate after reducing pressure and temperature.

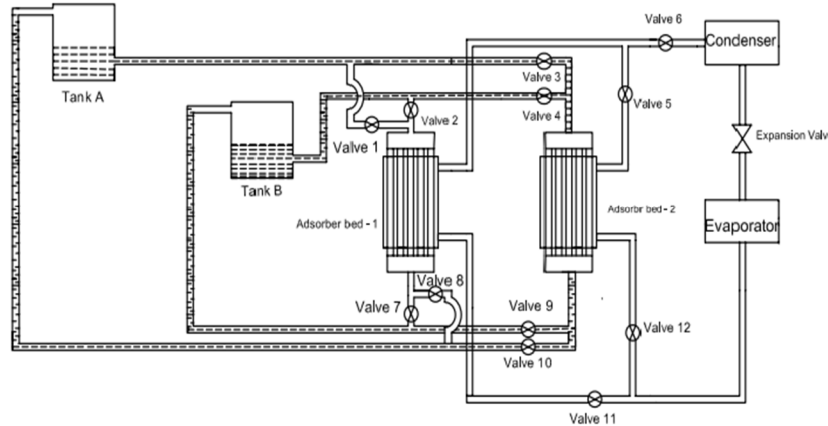

Figure 1. Working cycle of Vapour Adsorption Refrigeration

Here, Tank A contains hot water and tank B contain cold water. Both tank is connected to both adsorber bed separately provided with valve at inlet and outlet. Same way, evaporator is connected to inlet of each adsorber bed and Condenser is connected at the out of each adsorber bed provided with valve.

As vapour refrigerant is coming out from the evaporator at high temperature and presser it goes to either of adsorber-2. In adsorber bed-2 cold water is passing inside the tubes while vapour refrigerant moves through the shell side of adsorber bed which contain adsorbent. Adsorbent will adsorb adsorbent on it which is refrigerant only. Therefore heat transfer happens between vapour refrigerant and cold water in terms of adsorption. This process is known as adsorption process.

This vapour refrigerant then goes to condenser which converts it into liquid refrigerant. From outlet of the condenser it passes through the expansion valve and then evaporator. This cycle continuously happens until adsorber bed is fully charged. When adsorbent inside adsorbed has adsorb adsorbent up to its maximum limit then it is fully charged and cycle can't proceed further. It need to be discharged. This can be achieved by allowing hot water through the tubes of adsorber bed.

While, this discharge of adsorber bed-2 is happening adsorber bed-1 is ready to serve. Hot refrigerant will pass through the shell of adsorber bed-2 which contain adsorbent same as adsorber bed-2 and cold water will pass through the tubes of adsorber bed-1. Heat transfer will occur between refrigerant and cold water through adsorption process.

By the time adsorber bed-1 will fully charge and adsorber bed-2 will be available for process. This cycle continuously goes on.

Depending upon the adsorption and desorption process in Adsorber bed-1 or adsorber bed-2 valves are open and closed. It can be seen from table that during desorption process refrigerant doesn't flow. For single adsorber bed cycle this can be lag time, during this period system doesn't work. For double bed refrigeration discharge of refrigeration can be done parallel while adsorption process happens in other one. So, system continues to work without stopping.

Table 1. Flow through valves with respect to process

Case	Scenario	Water Cycle	Refrigerant Cycle
1	Adsorption in bed - 1	TankB-Valve 4-Valve 9-Tank B	Eva. – Valve11-A.bed1 – Valve6 – Valve11-Cond.-Eva.
	Desorption in bed -2	Tank A – Valve3-A.bed2-Valve 10-Tank A	-
2	Desorption in bed - 1	TankA-V1-V8 – TankA	-
	Adsorption in bed - 2	Tank B – Valve4 – Valve9-Tank B	Eva. – Valve12-A.bed2-Valve5-Cond.-Eva.

3. NOMENCLATURE

Table 2. Symbols used in article

Symbols	Names
Q_{ref}	Heat Energy
m	Mass
c_p	Specific heat at constant pressure
dT	Temperature difference
m_f	Mass flow rate
A	Area of cross-section
G_t	Mass velocity
Re	Reynolds number
μ	Dynamic Viscosity
h	Heat transfer co-efficient
j_h	Chilton and Colburn dimensionless factor
K	Thermal conductivity
Pr	Prandtl number
Nu	Nusselt Number
LMTD	Logarithmic mean temperature difference

4. DESIGN CALCULATION

4.1. Mass of Adsorbate and Adsorbent

Mass of Adsorbate can be determined by cooling requirement of product, i.e. water.

$$Q_{ref} = m_w c_{pw} dT \quad (1)$$

And

$$m_{f/ref} = Q_{ref} / h_{fg} \quad (2)$$

With the help of Dubinin Astakhov correlation the value of adsorption capacity is achieved.

$$x = m_{ref} / m_{ads} \quad (3)$$

From the above equation, mass of adsorbent is calculated.

4.2. Adsorber bed Design

As discussed above adsorber bed is key component of the cycle. It is one type of heat exchanger in which heat transfer happens between hot/cold water and refrigerant with the help of adsorbent. Here, shell and tube type of heat exchanger is considered. Inside the tubes of heat exchanger cold water is supplied during adsorption cycle and hot water is supplied during desorption cycle. Shell is contained with adsorbent and adsorbate(refrigerant) flows through shell. For better heat transfer sometimes fin is provided on the tubes.

Heat Duty in adsorber bed

$$Q_{ads} = m_m c_{pm} dT_m \quad (4)$$

Overall heat transfer coefficient can be calculated by separately calculating tube side and shell side heat transfer coefficient.

Flow area per pipe

$$A_t = \pi r^2 \quad (5)$$

Mass Velocity

$$G_t = m_w / A_t \quad (6)$$

Reynolds number

$$Re_t = (D * G_t) / \mu \quad (7)$$

Tube side heat transfer coefficient

$$h_i = j_h \left(\frac{k}{D}\right) (c_p \mu / k)^{0.33} (\mu / \mu_t)^{0.14} \quad (8)$$

Where, j_h is Chilton and Colburn dimensionless factor.

Including thickness of the tube, the corrected heat transfer coefficient is given by

$$h_{io} = (h_i * d_i) / d_o \quad (9)$$

Shell side heat transfer coefficient

$$h_s = a_0 Re^{0.6} Pr^{0.33} / F_s (K_f / d) \quad (10)$$

Overall heat transfer coefficient

$$(h_o) = (h_s * h_{io}) / (h_s + h_{io}) \quad (11)$$

Considering, counter flow arrangement LMTD can be determined.

Area of contact(A_c)

$$A_c = Q_{ads} / (h_o * LMTD) \quad (12)$$

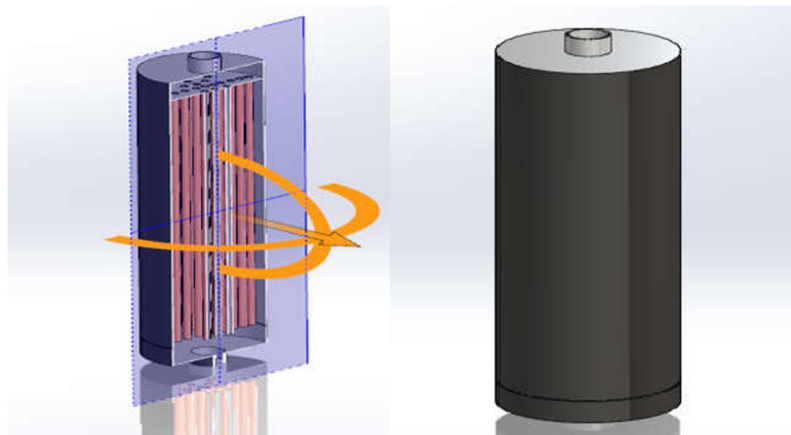

Figure 2. Design of Adsorber Bed

4.3. Condenser Design

Condenser converts the vapor refrigerant into liquid refrigerant. It can be considered as shell and tube type of heat exchanger. Dimensions of the condenser can be calculated in the same way as adsorber bed. Here, inside the tube refrigerant will flow and inside the shell water will flow. The temperature difference between refrigerant and water will cause heat transfer process.

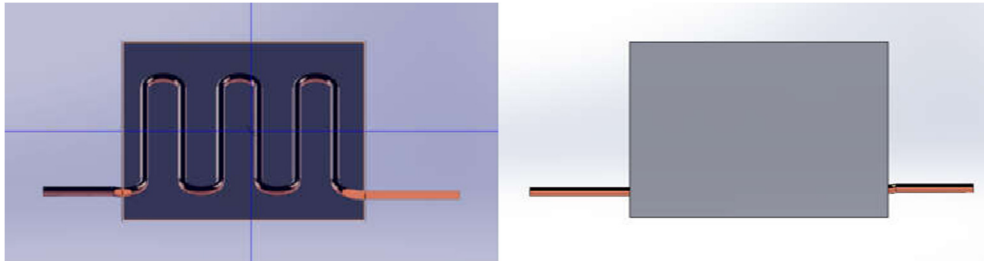

Figure 3. Design of Condenser

4.4. Evaporator Design

The evaporator is considered as shell and coil type heat exchanger. Dimensions of the coil and shell can be calculated by the mass velocities of the fluid.

For laminar flow, shell side heat transfer coefficient (h_o)

$$h_o = 0.6 Re^{0.5} Pr^{0.31} (K/D) \quad (13)$$

Tube side heat transfer coefficient (h_i)

$$h_i = j_h (K/D) (Nu * Pr)^{0.33} \quad (14)$$

Corrected tube side heat transfer coefficient

$$h_{io} = h_i (D/Do) \quad (15)$$

Overall heat transfer coefficient

$$h_o = (1/h_s) + (1/h_{io}) + (t/k) + R_c + R_s \quad (16)$$

where, t is coil thickness, K is thermal conductivity of coil material, R_c and R_s are fouling factors for coils and shell respectively.

Contact area of coil (A_c)

$$A_c = Q_{ref} / (h_o * LMTD) \quad (17)$$

Where, LMTD is calculated by considering counter flow arrangement.

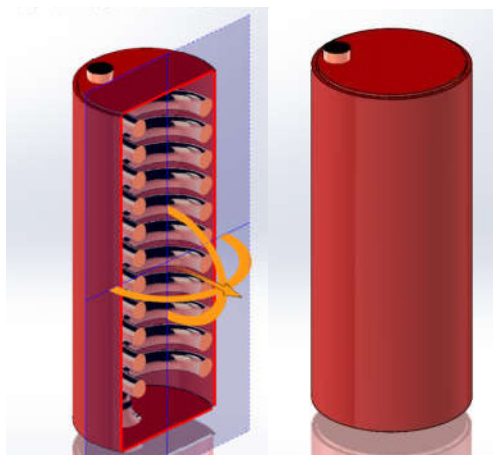

Figure 4. Evaporator Design

5. CONCLUSION

The calculation shows that adsorption refrigeration cycle is good option to serve purpose of refrigeration and advantages over vapour compressor refrigeration. Low specific cooling power leads to bigger size of chiller which increase investment cost. Table 3 shows optimum dimensions of components calculated here. Here, standard size copper pipe is considered for simplicity in fabrication work.

Table 3. Dimensions of Components

Component	Type	Specification
Adsorber bed	Shell and tube	Shell 140 mm in diameter, 800 mm long 9.52mm (3/8 inch) tube dia.
Condenser	Shell and tube	Shell of capacity 23L 1.6m long tube with 12.7mm (1/2 inch) of dia.
Evaporator	Shell and helical coil immersed in water	Shell 10L 6m long tube with 12.7mm (1/2 inch) of dia.

6. REFERENCES

- [1] *A Case Study of a Low Power Vapour Adsorption Refrigeration System* M. Young, *The Technical Writer's Handbook*. Mill Valley, CA: University Science, 1989.
- [2] Ojha, M. K., Shukla, A. K., Verma, P., & Kannojiya, R. (2021). *Recent progress and outlook of solar adsorption refrigeration systems*. *Materials Today: Proceedings*, 46, 5639-5646.
- [3] Elsheniti, M. B., Elsamni, O. A., Al-dadah, R. K., Mahmoud, S., Elsayed, E., & Saleh, K. (2018). *Adsorption refrigeration technologies*. *Sustainable air conditioning systems*, 71-95.
- [4] Tiwari, H., & Parishwad G. V. (2012). *Adsorption refrigeration system for cabin cooling of trucks*. *International journal of emerging technology and advanced engineering*, 2(10), 337-3 2.
- [5] Patel, J. K., Mehta, N., & Dabhi, J. (2017). *Adsorption Refrigeration System: Design and Analysis*. *Materials T day: Proceedings*, 4(9), 10278-10282.

- [6] Wang, R. Z., & Oliveira, R. G. (2006). *Adsorption refrigeration—an efficient way to make good use of waste heat and solar energy*. *Progress in energy and combustion science*, 32(4), 424-458.
- [7] Choudhury, B., Saha, B. B., Chatterjee, P. K., & Sarkar, J. P. (2013). *An overview of developments in adsorption refrigeration systems towards a sustainable way of cooling*. *Applied Energy*, 104, 554-567.
- [8] Zhao, C., Wang, Y., Li, M., Zhao, W., Li, X., Du, W., & Yu, Q. (2020). *Experimental study of a solar adsorption refrigeration system integrated with a compound parabolic concentrator based on an enhanced mass transfer cycle in Kunming, China*. *Solar Energy*, 195, 37-46.
- [9] Alok, P., & Sahu, D. (2018, June). *Experimental Study on Vapor Adsorption Refrigeration System with Carbon-Methanol Pair*. In *IOP Conference Series: Materials Science and Engineering* (Vol. 376, No. 1, p. 012086). IOP Publishing.
- [10] Singh, S., & Dhingra, S. (2019, July). *Thermal performance of a vapour adsorption refrigeration system: an overview*. In *Journal of Physics: Conference Series* (Vol. 1240, No. 1, p. 012024). IOP Publishing.
- [11] Wang, L., Bu, X., & Ma, W. (2018). *Experimental study of an adsorption refrigeration test unit*. *Energy Procedia*, 152, 895-903.