

Advanced Dual Boost Inverter with High Voltage Gain DC to DC topology for PV Applications

Priya.R¹, Mr.N.Amarabalan², R.Revathy³

^{1 & 2} Department of EEE, Manakula Vinayagar Institute of Technology, Puducherry, India

³ Department of EEE, IFET College of Engineering, Villupuram, India

Abstract: *A novel dual boost inverter with high voltage gain DC to DC converter for PV system application is analyzed in this paper. This new topology comprises of modified Dickson charge pump based voltage multiplier circuit at the front end and dual boost inverter on its next end. The notable advantages of this proposed converter circuits are boosting the DC voltage levels and inversion of DC to AC with a cost effective structure. The output of a fundamental full-bridge inverter always appears to be less than the DC voltage input. In order to resolve this issue, DC chopper is added at the front end of the converter to boost the AC voltage comparatively greater than the DC input Voltage. The blend of front end chopper and inverter bestows to a two-stage power conversion process. The conventional boost inverter has drawbacks like poor efficiency, discontinuous current operation, requirement of large capacitors, large duty cycle and EMI issues. In this paper, the combination of the modified Dickson charge controller with dual boost inverter is proposed to acquire benefits like compact circuit structure, reduction in number of circuit components with boosting capability. The conventional full cycle modulation scheme in the dual boost inverter leads to operation of power devices at the higher frequency ranges through the full cycle. The voltage/current stress across the switching devices sequentially increases the losses associated with the circuit. So HCM modulation scheme is proposed to reduce the switching stress and switching losses. Furthermore, in order to address the current circulation losses, the clamping switches are added with the DBI inverter. The Dual boost inverter with modified Dickson charge voltage multiplier circuits are simulated and the hardware prototype model is also constructed to validate the simulation results.*

Keywords:

Modified Dickson charge pump, Dual boost inverter, interleaved boost converter Voltage Multipliers, Half cycle modulation, Clamp switch

1. INTRODUCTION

Energy plays an crucial role to ensure the quality of life and to support all other progress of our nation. In the recent years, the consumption of energy has amplified and hence resulted in a huge demand. The renewable energy resources are playing a significant role to address the ever demanding energy needs. The Power generation processes using the traditional sources like coal and oil will increase the greenhouse effect and impact the environment. The deficiency in energy generation process and pollution issues can be considered as a main burden for growth of Industries. These concerns make the government entities, researchers, investors and other stock holders to focus more on the clean energy resources.

The right utilization of renewable energy resources is considered as one of key policy to reduce the dependence on fossil fuels and emissions of GHGs. The photovoltaic (PV) can be considered as a unique resource due to its reliability, sustainability, maintenance free and cost effectiveness. The voltage generated by the renewable energy resources like PV panels will be in the nature of DC voltage. Therefore it needs a double stage conversion process, at the first DC to DC conversion to boost up the DC voltages and then inversion process to convert the DC into AC.

DC-DC converter models and inverters have fascinated the interest of numerous people due to its proficiency of converting the voltage levels.

2. EXISTING BOOST CONVETER AND INVETER TOPOLOGIES

Some of the conventional boost converters, voltage-doublers, multiplier circuits, charge pump circuits and inverter topologies are discussed in this section.

2.1. Traditional boost converter

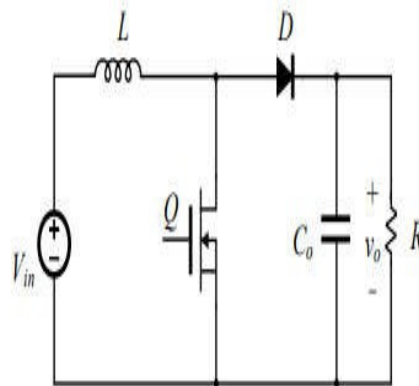

Figure 1.1 Traditional boost converters

The requirement to change an input DC voltage into a variable DC voltage is achieved via adopting the boost converter. It can be considered as an equivalent of transformer, in which boosting of AC is obtained. Simple boost converter circuit is shown in Figure 1.1. $V_o = V_{in} / (1 - d)$ is used to find the output voltage of the boost converter. Here d is Duty cycle parameter. The key element of the circuit is inductor, but the physical size of the inductor is huge, which makes issue while integrating it in the circuit. The basic converter is operated at higher duty cycle values leads to voltage stress, switching losses and low efficiency.

2.2. Cascaded and Stacked Boost Converters

The switches must be operated at greater duty cycles in order to maximise efficiency. Switching losses are directly proportional to the operating duty cycle. So to improve voltage gain, the boost converters are connected in cascaded manner termed as stacked boost converters. The impact of conventional boost converters like high switching stress and high switching loss due to high duty ratio do not exist in this cascaded connection. In case of an ideal cascaded boost converter, the voltage gain will be computed using the equation $V_o = V_{in} (1 - d)^{-2}$. Overall voltage gain is the product of gains of individual boost converters. $H_{stack} = \eta_1 * \eta_2$. If m number of conventional boost converters are connected in cascaded manner, then the overall voltage gain computed as $V_o = V_{in} (1 - d)^{-m}$. The multiple power processing stages in the cascaded connection in turn results in efficiency reduction.

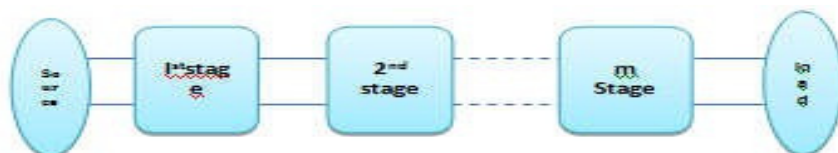

Figure 1.2 Cascaded /stacked boost converters

2.3. Voltage multipliers

The voltage multiplier circuits constructed by the ladder network connection. The Voltage Multiplier Circuit (VMC) is categorized as Dickson charge and Cockcroft-Walton VMC based on methods of capacitors connection. It's perceived from the circuit diagram of Dickson Voltage Multiplier, the capacitors negative ends are connected to Phase A and Phase B. Difference between the Cockcroft-Walton VMC and Dickson Voltage Multiplier lies in the connection the capacitors. Unlike Dickson Voltage Multiplier, negative end of odd capacitor and positive end of the previous odd capacitors are connected together and similarly, negative end of even capacitor and positive end of the previous even capacitors are connected together in the Cockcroft-Walton VMC. Higher voltage gain, small voltage stress across the circuit elements, compactness are the major advantages of voltage multipliers. These converters are lighter and cheaper. This model eliminates the need for a transformer with heavy core and insulation to boost voltage levels.

2.4. Dickson charge Multipliers

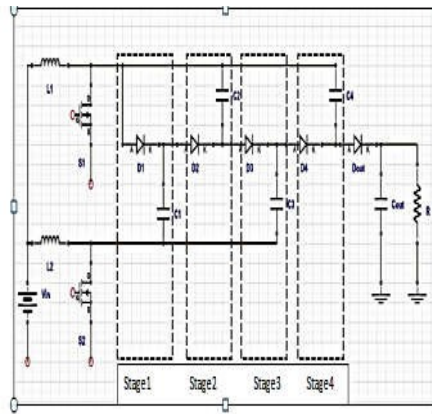

Figure 1.3 Dickson charge pump-High Voltage DC-DC converter

DC system has numerous benefits over an AC distribution system like higher efficiency and reliability, reduced installation costs, easy integration with renewable energy resources and free from synchronization issues. The output of the PV panels is DC and it can be directly applied to the DC loads without any conversion stage. But if the requirement of DC voltages is higher, then there is a need for high-voltage-gain converters.

In addition to that, to feed the output of Solar panel to AC loads, certainly a power conversion stage is essential in order to convert DC to AC. The process of boosting the voltage from 20V /40V DC to 400 V DC is a complex process. If simple boost and buck-boost converters are used, the switches must be operated under high duty ratio situations, resulting in high stress and lower efficiency. In order to address these issues, the two converters can be connected in cascaded mode. Isolated topologies like fly back converter, half and full-bridge converter have intermittent input currents and henceforth need bulky input capacitors. All these issues will be addressed in the Dickson charge controller circuits.

The Dickson charge type voltage Multiplier circuit is shown in the fig(1.3). The input voltage will be multiplied at the end of each of the capacitor section. If the input voltage is considered as N level, then at the each stage, the output voltage obtained is in the order of $2N, 4N, 6N$ and $8N$ in a four stage multiplier circuit.

2.4. Boost inverter: Inverter coupled with chopper

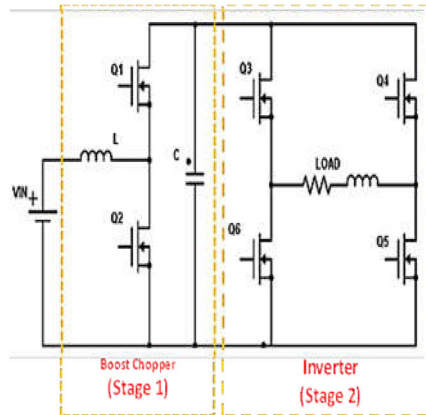

Figure 1.4 Dual stage boost inverter with Chopper at front end

Generally, the output voltage of single phase voltage source inverter is found lesser than the DC input voltage. Hence it is not adopted in high level applications. Therefore cascaded topologies and multilevel topologies are used to boost the level of output voltage. To increase front end DC voltage level, an additional DC-DC conversion stage is implemented in addition with an inverter. Therefore boost inverter as per fig 1.4 has two stage conversion levels, i.e. DC-DC boosting and DC to AC conversion by an inverter which yields to circuit complexity. More number of switches in association with more switching loss is the main concern in this category of converter. Hence a DBI with modified Dickson charge converter has been proposed in this paper with less power devices and improved boosting ability.

3. PROPOSED SYSTEM

3.1. Modified Dickson Charge Pump Voltage Multiplier

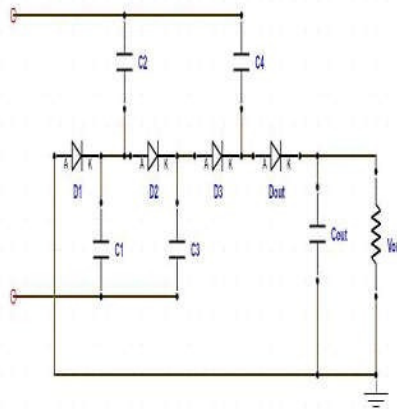

Figure 3.1. Modified Dickson Charge Pump

The topology with minimum components, higher voltage gain, compactness and higher power density are the essential parameters of an ideal topology. Meanwhile, designing a new power electronics converter, various parameters like no of switches, switching stress and loss, High power density, Heat dissipation, harmonics/ripples, efficiency with cost will be considered as prominent data's. Modified Dickson charge controller has reduced number of components and the size of capacitor is also reduced due to reduction in the voltage stress.

The main benefits of the modified converter include continuous output current and reduced voltage stress across switches, making the modified Dickson charge converter ideally suited for renewable energy applications, particularly for increasing the DC voltage outputs of solar panels. The identical current stress across the inductors and switches makes the component selection process of

this converter as a simpler work. Modified Dickson charge pump circuit as shown in Fig.3.1. The voltage levels across the capacitors are moderately low. The High gain boost converter topology using the modified Dickson charge pump is shown in the fig 3.2.

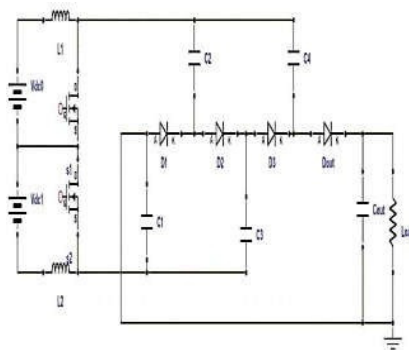

Figure 3.2. High gain Dc to DC converter with Modified Dickson Charge Pump

4. MODES OF OPERATION

4.1 Mode I:

In this mode 1 Fig 4.1, switches Q1 and Q2 of the two phase interleaved boost converter are kept at ON state. V_{dc0} and V_{dc1} will charge the inductors L1 and L2 respectively and the inductor currents i_{L1} and i_{L2} will start to rise linearly. Diodes D1, D2, D3 and Dout of the modified Dickson charge converter unit remains at reverse biased condition and hence they are at OFF mode. The voltages across the modified Dickson charge controller capacitors remain as the same. Because the Dout diode is likewise turned off, the load is supplied by the output capacitors.

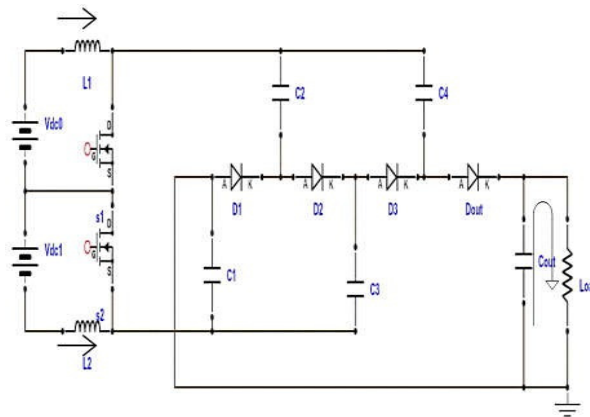

Figure 4.1 Mode I operation of Modified Dickson charge pump

4.2 Mode II:

Considering the mode 2 operation, Q1 off and Q2 maintained in the ON state. D1 and D3 reverse biased condition and hence they are at OFF state. The other two diodes D2 and Dout are in forward bias condition and hence at the ON state. The current i_{L1} flows through capacitor C2 to charge it. The diode D2 is under forward biased condition, the current i_{L1} will also flow through the capacitor C3 to charge it. Remaining current of i_{L1} will flow through the capacitor C4 and C1 will start to charge the output capacitor Cout and load.

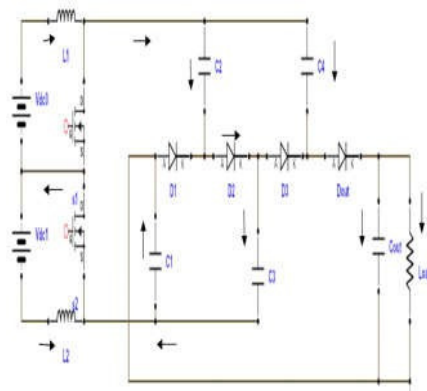

Figure 4.2 Mode II operation of Modified Dickson charge pump

4.3 Mode III:

This mode is the reversal operation of the mode II. (i.e.) Q1 is turned ON and Q2 off. D1 and D3 are under ON . Diodes D2 and Dout are under reverse bias condition. As the switch Q1 turned ON, Inductor current i_{L2} flow via C1, C2, C3, and C4. The Capacitors C1 and C4 are under charging process while C2 and C3 are at discharging process.

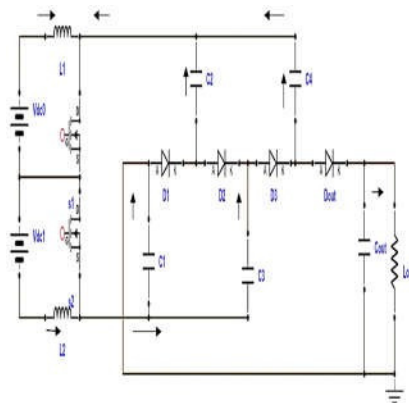

Figure 4.3 Mode III operation of Modified Dickson charge pump

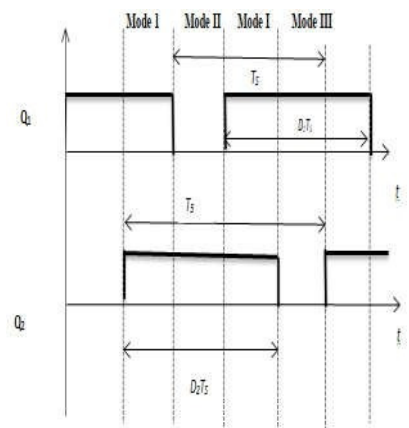

Figure 4.4 Switching signals for the switches Q1 & Q2 of modified Dickson charge converter

In this mode III, the output capacitors feeling the load. Switching sequence of Q1 and Q2 are indicated in the Figure 4.4.

5. DUAL BOOST INVERTER

5.1 Dual boost inverter with HCM Scheme

Implementation of traditional modulation schemes (full cycle modulation) makes the power switches to operate at higher frequency ranges. It will considerably increase the conduction and switching losses. Hence, the adoption of new modulation schemes is required to improve the work efficacy of the circuit. The half cycle modulation (HCM) strategy with Dual boost inverter is analyzed to reduce the above said issue. In addition to that, the current circulation losses will be reduced with the inclusion of two clamping switches. The addition of clamping switch provides the bypass path for the inductor current and consequently the losses caused by circulation current significantly reduced. Hence, this improved topology of DBI with clamping switches will result in higher efficiency with low switching stress across its elements. The switching signal generated with the half cycle modulation is shown in figure 5.1.

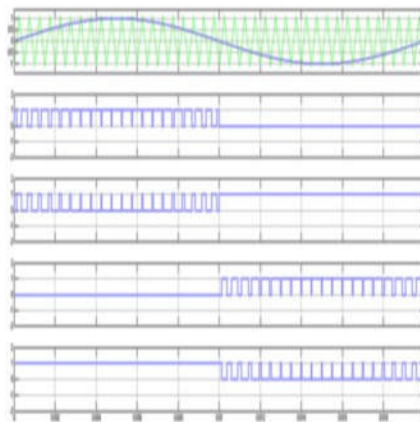

Figure. 5.1 HCM scheme of the DBI without clamping switches

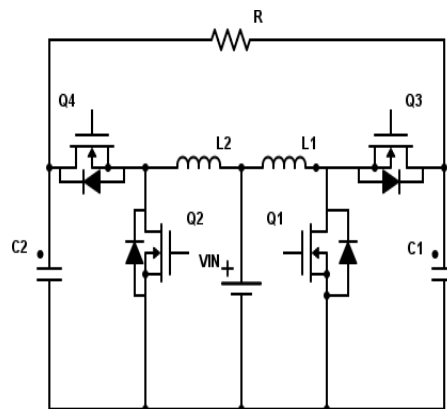

Figure. 5.2 Dual boost inverter without clamping switches

Dual boost circuit diagram of inverter without clamping switch topology is shown in fig 5.2. It is constructed with four power switches, indicated as Q1, Q2, Q3 and Q4. Voltages measured across C1, C2 capacitors are taken as V_0 , DC voltage at supply side represented as V_{IN} , V_m is the output AC voltage. For the duration of the positive half cycle, Q1 and Q3 will be turned ON and during the next half cycle period Q2 and Q4 will be turned ON in complementary mode.

5.2 Operating modes of DBI without Clamping Switches

- Mode 1 [t_0, t_1]: At t_0 , Q1 and Q4 turned on, input voltage is applied and L1 starts its charging process through the input current. Load current i_0 will flow through Q4(D4) to V_{in} , which supplied by C1.
- Mode 2 [t_1, t_2]: The period is dead time. At t_1 , Q1, Q2, Q3 are turned off, Q4 is turned on, the current i_{L1} flow through D3 or D1 (according to the direction of current), Load current i_0 will flow through Q4(D4) to V_{in} .
- Mode 3 [t_2, t_3]: At t_2 , Q3 is turned on, i_{L1} flow through Q3 (D3). Load current i_0 flow through Q4 (D4) to V_{in} .
- Mode 4 [t_3, t_4]: This is also a dead time period, and its operation is similar to mode 2. At this period, the measured voltage is negative.
- Mode 5 [t_6, t_7]: At t_6 , Q2, Q3 are turned on, the input voltage is applied and the input current charges L2. Load current i_0 will flow through Q3 (D3) to V_{in} , which supplied by C2.
- Mode 6 [t_7, t_8]: This duration is also dead time. At instant t_7 , Q1, Q2, Q4 are turned off, Q3 is turned on, i_{L2} flow through D4/ D2. Load current i_0 will flow through Q3(D3) to V_{in} .

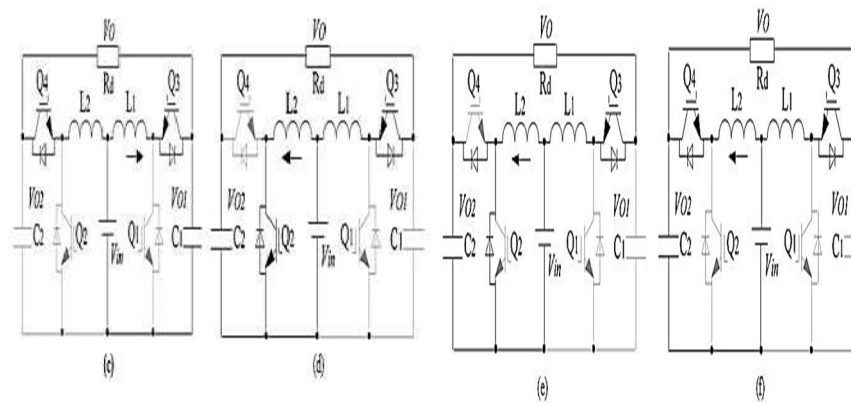

Figure. 5.3 Modes of operation at various instances (a) [t_0, t_1], (b) [t_1, t_2] or [t_3, t_4], (c) [t_2, t_3], (d) [t_6, t_7], (e) [t_7, t_8] or [t_9, t_{10}] and (f) [t_8, t_9].

5.3 Dual boost inverter with clamping switches

Operation of dual boost inverter without clamping switch is explained under the Section B. The adaption of half carrier modulation scheme resulted with the reduction in switching losses. But the Current circulation issues with its associated losses still persists in the proposed converter circuit. In order to address this issue, a new topology with clamp devices is suggested. In this topology, only one inductor is used for boosting operation and the at the output side, clamping switch is associated to clamp the input voltage V_{in} . The operating frequency of the clamping switches is maintained as equivalent to the line frequency, which gives the advantage of lower voltage stress.

Cost effective switches like MOSFET can be employed in the circuit in comparison with the IGBT in the identical condition. The circuit of the proposed DBI with clamping switches is shown in Fig 5.4.

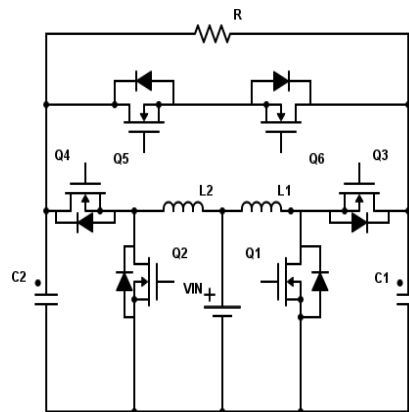

Figure.5.4 Dual boost inverter with clamping switches

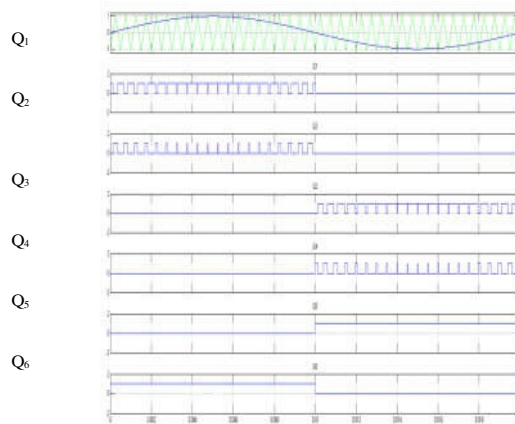

Figure 5.6 HCM Scheme of DBI with clamping switches

5.4 Modes of Operation of DBI with Clamping Switches

- a) Mode 1 [t_0, t_1]: At t_0 , Q_1, Q_4 is switched on; the input voltage is supplied to L_1 and the input current flows and charges the Inductor L_1 . Load current i_0 will flow through Q_4 (D_4) to V_{in} , which is supplied by C_1 .
- b) Mode 2 [t_1, t_2]: The period is dead time. At t_1 instant, Q_1, Q_2, Q_3 are switched off and Q_4 is switched on, the current i_{L1} flows through D_3 or D_1 , as shown in Fig. 3.11(b). Now the Load current i_0 direction is via Q_4 (D_4) to V_{in} .
- c) Mode 3 [t_2, t_3]: At t_2 , Q_3 is turned on, i_{L1} flow through Q_3 (D_3). Load current i_0 flow through Q_4 (D_4) to V_{in} .

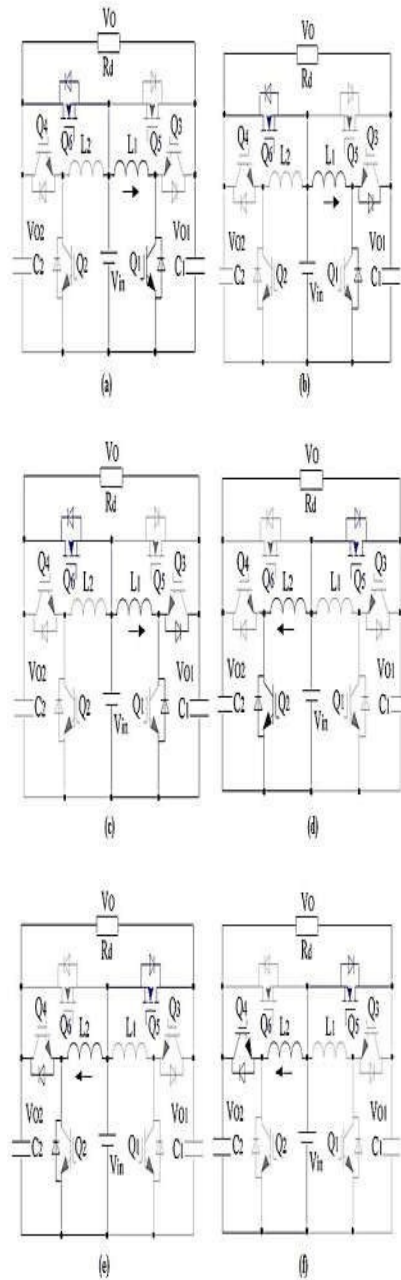

Fig 5.5 Equivalent circuits of switching modes (a) $[t_0, t_1]$, (b) $[t_1, t_2]$ or $[t_3, t_4]$, (c) $[t_2, t_3]$, (d) $[t_6, t_7]$, (e) $[t_7, t_8]$ or $[t_9, t_{10}]$ and (f) $[t_8, t_9]$.

Mode 7 $[t_8, t_9]$: At t_8 , Q_4 is turned on, i_{L2} flows through Q_4 (D_4). Now the Load current i_0 direction is via Q_3 (D_3) to V_{in} .

Mode 8 $[t_9, t_{10}]$: This final mode is also dead time period, with similar to mode 6

Mode 4 $[t_3, t_4]$: This mode 4 is also called as dead time period and the working process is same like Mode 2 with negative output voltage.

Mode 5 $[t_6, t_7]$: At t_6 , Q_2, Q_3 are switched on, the input voltage and the input current charges the inductor L_2 . Load current i_0 will flow through Q_3 (D_3) to V_{in} , which is supplied by C_2

Mode 6 $[t_7, t_8]$: It is again a dead time. At t_7 , Q_1, Q_2, Q_4 are turned off, Q_3 is turned on, the current i_{L2} flows through D_4 or D_2 . Load current i_0 will flow through Q_3 (D_3) to V_{in} .

Mode 7 [t_8, t_9]: At t_8 , Q_4 is turned on, i_{L2} flow through Q_4 (D_4). Load current i_o flow through Q_3 (D_3) to V_{in} .

Mode 8 [t_9, t_{10}]: This period is also dead time period with similar operation as mode 6.

5.5 Simulation parameters of the proposed system

Table 1: Matlab Simulation Parameters of DBI Without and with Clamping Switches

Parameters	Without clamping switch	With clamping switch
Supply voltage	50V	50V
Output voltage	68V	105V
Inductor	500 μ H	500 μ H
Capacitor	20 μ F	20 μ F
Inductive Load Parameter	-	5 μ H
Capacitive Load Parameter	2700 μ F	2200 μ F
Resistive Load Parameter	20 Ω	20 Ω
Sine wave Frequency	50 Hz	50 Hz
Carrier frequency (Triangular wave)	20KHz	20KHz
Duty Cycle	71%	71%
Switching Technique	HCM	HCM

Table 2: Matlab Simulation Of Modified Dickson Charge Pump

Parameter	Description
Input Voltage	20V
Output Voltage	400V
Load Resistance	800 Ω
Duty Cycle of Switches S1 and S2	80%
Switching Frequency	100kHz
Value of L_1 and L_2	100 μ H
VM Capacitor	60 μ F
Output Capacitor	22 μ F

5.6. Hardware implementation of the proposed

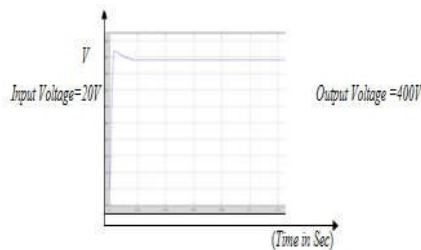

Figure 5.6 Output Voltage waveform of Dickson charge voltage multiplier unit system



Figure 5.7 Hardware Prototype

6. CONCLUSION

The combination of a two-phase interleaved boost converter at the front end and a modified Dickson charge pump voltage multiplier circuit at the rear end results in a new topology. DBI can be achieved as a one stage converter, which has advantages such as a simple structure, fewer components, and buck-boost capability. The suggested system employs HCM method, which causes power switches to operate at a high frequency for half of a cycle. To reduce current circulation losses, an enhanced DBI architecture with two clamping switches is also proposed. The DBI's modulation method caused all of the switches to operate at high frequencies. This resulted in significant voltage/current stress as well as high conduction and switching losses. The suggested half cycle modulation causes power switches to operate at high frequency for only half a cycle, reducing conduction and switching losses in power devices.

REFERENCES

- [1] R. Kadri, J.-P. Gaubert, and G. Champenois, An improved maximum power point tracking for photovoltaic grid-connected inverter based on voltage-oriented control, *IEEE Trans. Ind. Electron.*, vol. 58, no. 1, pp. 6675, Jan. 2011.
- [2] M. Berkhout and L. Dooper, Class-D audio amplifiers in mobile applications, *IEEE Trans. Circuits Syst. I, Reg. Papers*, vol. 57, no. 5, pp. 992 1002, May 2010.
- [3] E. K. Sato, M. Kinoshita, Y. Yamamoto, and T. Amboh, Redundant high density high-efficiency double-conversion uninterruptible power system, *IEEE Trans. Ind. Appl.*, vol. 46, no. 4, pp. 1525 1533, Jul./Aug. 2010.
- [4] S. V. Araujo, R. P. Torrico-Bascope, and G. V. Torrico-Bascope, Highly efficient high step-up converter for fuel-cell power processing based on three-state commutation cell, *IEEE Trans. Ind. Electron.*, vol. 57, no. 6, pp. 1987 1997, Jun. 2010.
- [5] Z. Amjadi and S. S. Williamson, Power-electronics-based solutions for plug-in hybrid electric vehicle energy storage and management systems, *IEEE Trans. Ind. Electron.*, vol. 57, no. 2, pp. 608 616, Feb. 2010.
- [6] L. G. Junior, M. A. G. Brito, L. P. Sampaio, and C. A. Canesin, Integrated inverter topologies for low power photovoltaic systems, in *Proc. Int. Conf. Ind. Appl.*, 2010, pp. 15.
- [7] S. V. Araujo, R. P. Torrico-Bascope, G. V. Torrico-Bascope, and L. Menezes, Step-up converter with high voltage gain employing three-state switching cell and voltage multiplier, in *Proc. Power Electron. Spec. Conf.*, 2008, pp. 2271 2277.
- [8] R. A. da Camara, C. M. T. Cruz, and R. P. Torrico-Bascope, Boost based on three-state switching cell for UPS applications, in *Proc. Brazilian Power Electron. Conf.*, 2009, pp. 3133 18.
- [9] L. Huber and M. M. Jovanovic, A design approach for server power supplies for networking, in *Proc. Appl. Power Electron. Conf. Expo.*, 2000, pp. 1163 1169.
- [10] X. G. Feng, J. J. Liu, and F. C. Lee, Impedance specifications for stable dc distributed power systems, *IEEE Trans. Power Electron.*, vol. 17, no. 2, pp. 157 162, Mar. 2002.
- [11] Y. R. Novaes, A. Rufer, and I. Barbi, A new quadratic, three-level, dc/dc converter suitable for fuel cell applications, in *Proc. Power Convers. Conf., Nagoya, Japan*, 2007, pp. 601 607.
- [12] K. W. Ma and Y. S. Lee, An integrated flyback converter for dc uninterruptible power supply, *IEEE Trans. Power Electron.*, vol. 11, no. 2, pp. 318 327, Mar. 1996.
- [13] C. T. Choi, C. K. Li, and S. K. Kok, Modeling of an active clamp discontinuous conduction mode flyback converter under variation of operating condition, in *Proc. IEEE Int. Conf. Power Electron. Drive Syst.*, 1999, pp. 730 733.
- [14] K. C. Tseng and T. J. Liang, Novel high-efficiency step-up converter, *IEE Proc. Electr. Power Appl.*, vol. 151, no. 2, pp. 182 190, Mar. 2004.
- [15] O. Abutbul, A. Gherlitz, Y. Berkovich, and A. Ioinovici, Boost converter with high voltage gain using a switched capacitor circuit, in *Proc. Int. Symp. Circuits Syst.*, 2003, pp. III-296 III-299.
- [16] Y. Jang and M. M. Jovanovic, Interleaved boost converter with intrinsic voltage-doubler characteristic for universal-line PFC front end, *IEEE Trans. Power Electron.*, vol. 22, no. 4, pp. 1394 1401, Jul. 2007.

- [17] J. Yungtaek and M. M. Jovanovic, New two- inductor boost converter with auxiliary transformer, *IEEE Trans. Power Electron.*, vol. 19, no. 1, pp. 169 175, Jan. 2004.
- [18] R. Gules, L. L. Pfitscher, and L. C. Franco, An interleaved boost dc dc converter with large conversion ratio, in Proc. *IEEE Int. Symp. Ind. Electron.*, 2003, pp. 411416.
- [19] M. Prudente, L. L. Pfitscher, G. Emmendoerfer, E. F. Romaneli, and R. Gules, Voltage multiplier cells applied to non-isolated converters, *IEEE Trans. Power Electron.*, vol. 23, no. 2, pp. 871887, Mar. 2008.
- [20] C. E. A. Silva, R. P. Torrico-Bascope, and D. S. Oliveira Jr., Proposal of a new high step-up converter for UPS applications, in Proc. *IEEE Int. Symp. Ind. Electron.*, 2006, pp. 12881292