

PV-STATCOM-A SMART INVERTER IN DISTRIBUTION SYSTEM USING PARKS TRANSFORMATION

Mr.D.Muruganandhan
Electrical & Electronics Engineering
(Pondicherry University)
Manakula Vinayagar Institute Of
Technology
Puducherry ,India

Mr.J.Vijayaraghavan
Electrical & Electronics Engineering
(Pondicherry University)
Manakula Vinayagar Institute Of
Technology
Puducherry ,India

Abstract—The issue of voltage sag and its detrimental effects on sensitive or nonlinear loads are discussed in this paper. Among the most significant issues with power quality facing the utility sector is voltage sag. By adapting the typical solar inverter controller to perform as a STATCOM, the remaining inverter capacity after actual power generation during the day is used in this, and the overall setup is referred to as PV-STATCOM. This can be applied to the relevant grid to enhance voltage regulation, power factor correction, and reduce total harmonic distortion during the day. The smart inverter briefly stops producing real power during a daytime critical system disturbance and releases all of its inverter capacity for STATCOM operation. To reduce the sag and raise the calibre of the power, Parks Transformation is employed. MATLAB/SIMULINK is used to simulate the suggested method.

Keywords—*component, formatting, style, styling, insert (key words)*

I. INTRODUCTION (HEADING 1)

The significance of Power Quality (PQ) has increased significantly over the past two decades as a result of, among other things, a noticeable rise in the amount of equipment that is sensitive to poor PQ environments, disruptions caused by nonlinear load, and the spread of renewable energy sources. The voltage quality type is to blame for more than 50% of all Power Quality disruptions. The voltage sags and expands, periodic & interharmonic voltages, and voltage imbalances for three-phase systems are the most well-known disturbances.

Voltage sag is a brief drop in Root mean square voltage of between 0.1 and 0.9 per unit, lasting anywhere from a half-cycle to a minute. Or, to put it another way, it is the abrupt decrease of supply voltage to between 90% and 10% of standard voltage. It is typically brought on by power system problems and distinguished by its size and length. The total RMS voltage during voltage sag is what is known as the voltage sag magnitude and is typically expressed in units of the original voltage level. The size of the voltage sag is affected by a number of variables, including the fault type, fault location, and fault impedance.

The length of the voltage sag essentially depends on how quickly the protective mechanism clears the fault. Voltage sag will persist until the fault is repaired, to put it briefly. There are numerous specialized power equipment. Active power filters (APF), Battery energy Storage (BESS), UPFC(Unified Power flow controller), STATCOM(static synchronous compensator), and Uninterruptible power supply are a few of these gadgets [1] [2].Each Custom Power gadget has unique advantages and restrictions. The

STATCOM (Static Synchronous Compensator) is said to be the most efficient version of these devices.

The STATCOM is favored above the others for a variety of reasons. The following list includes a handful of these explanations. Although the STATCOM predates the SVC, it is nevertheless favored because the SVC cannot regulate active power flow [3]. Another justification is the fact that the STATCOM is less expensive than the UPS(Uninterruptible Power Supply) [4, 5]. The UPS is expensive, but it also needs a lot of care because the batteries leak and need to be replaced as frequently as every five years [5]. In addition, the STATCOM costs less and has a better energy capacity than the(Super Conducting magnetic energy storage) SMES device [3]. Furthermore, the STATCOM is less expensive and smaller in size than the DVR(Dynamic Voltage Restorer) [3-16]. These factors explain why the STATCOM is commonly regarded as a powerful tailored power solution for reducing voltage sags and reliability issues [6]. In addition to compensating for voltage peaks and valleys, STATCOM can also add features like harmonics and Power Factor adjustment. The STATCOM certainly offers the finest financial remedy for its size and capabilities when compared to the other devices.

In addition to PV(photo voltaic) and its working concepts, STATCOM is introduced in this study. By correcting for real and reactive power, Parks transformation is used to enhance the quality of the electricity. Results from the simulation using MATLAB are shown and discussed at the conclusion. In order to compensate for voltage sags and swells that occur in distribution systems under atypical circumstances, the PV system works in tandem with the STATCOM, a shunt-connected flexible ac transmission systems (FACTS) controller.

II. STATCOM

On alternating current electrical transmission networks, a static synchronous compensator (STATCOM), also referred to as a static synchronous condenser (STATCON), is a regulating device. It is based on a voltage-source converter for power electronics and can supply or drain reactive AC power to a network of electrical outlets. It can also deliver active AC power if it's linked to a power source. It belongs to the FACTS family of gadgets. It is electable and modular by nature. Synchronous in STATCOM refers to the ability to generate or absorb reactive power in synchrony with the need to maintain the power network's voltage. A solid-state-based power converter called the STATCOM replaces the SVC. It can function as a shunt-connected SVC and its terminal AC bus voltage can't be used to control the capacitive or inductive output currents. Power converters have the ability

to switch quickly, hence STATCOM responds considerably more quickly than the SVC(Static VAR compensator).

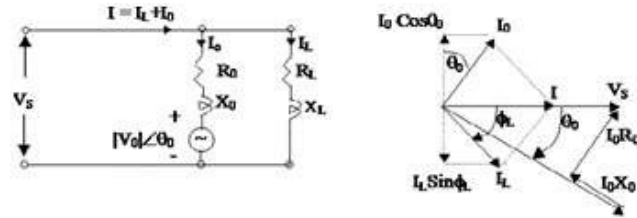

Fig.1. Inductive mode of operation

III. PV-STATCOM

When the sun is not shining well, a typical solar plant is not used. Both solar power plants and STATCOM depend heavily on voltage source inverters. To enhance the regulation of voltage and power factor, a solar power plant is therefore employed as STATCOM during times of darkness. Load current decreases when power factor improves.

Additionally, the system is more effective and has fewer transmission losses, maintaining its balance. The outcomes of the simulated distribution system support these claims. As a result, the distribution system's electrical performance and power quality are enhanced.

The voltage source for a STATCOM is a voltage source converter (VSC), which is housed behind a reactor. A STATCOM has limited active power capabilities because the voltage source is made from a DC capacitor. However, when an appropriate device to store energy is coupled across the DC capacitor, its operational power ability can be increased. The magnitude of the voltage source determines the reactive power at the STATCOM's terminals. For instance, the STATCOM produces reactive current if the VSC's terminal voltage is greater than the voltage of the alternating current at the point of connection; alternatively, it absorbs reactive power if the voltage source's amplitude is less than the AC voltage. Because the voltage source converter's IGBTs have quick switching times, a STATCOM's response time is faster when compared to that of a static VAR compensator (SVC). Given that the reactive power from a STATCOM reduces linearly with the AC voltage, it also offers more accurate reactive power support at minimal AC voltages than an SVC

A. Operative modes of STATCOM

The STATCOM operates in two modes for a steady state operation in a power system for maintaining grid discipline and stability. In order to maintain voltage and current at the load end constant and to meet the consumer demands the STATCOM operates in one of these modes, the two modes of operation are capacitive mode and inductive mode.

B. Capacitive mode

When the load is inductively charged, the STATCOM supplies the reactive power it requires. Figure.1 shows an equivalent circuit and phasor diagram

Here, the phasor diagram can be used to derive the following relations:

$$\text{The reactive power drawn by the,} \\ \text{Load} = V_s I_L \sin\Phi_L \quad (1)$$

$$\text{The reactive power supplied by,} \\ \text{STATCOM} = V_s I_0 \cos\theta_0 \quad (2)$$

For unity power factor operation,

$$V_s I_L \sin\Phi_L = V_s I_0 \cos\theta_0 \quad (3)$$

$$\text{Power loss in STATCOM, it is given by} \\ I_0^2 R_0 = V_s I_0 \sin\theta_0 \quad (4)$$

This power loss will be filled by the ac system. In conclusion, the STATCOM system's inverter will generate output voltage V_0 with the correct magnitude $|V_0|$ and phase θ_0 so that I_0 's reactive component, $I_0 \cos\theta_0$, cancels out the load current's reactive component, $I_L \sin\Phi_L$, resulting in operation with a unity power factor.

C. Inductive modes

For this mode, two exceptional instances are explored. When the load is capacitive and the STATCOM must absorb the reactive power produced by the load, as shown in Figure

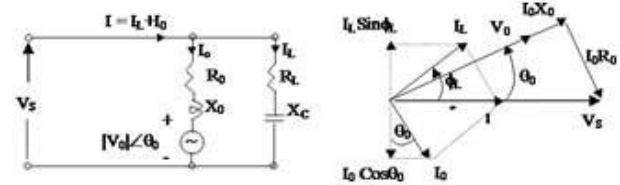

Fig.2. Inductive mode of operation

The generated load's

$$\text{Reactive Power} = V_s I_L \sin\Phi_L \quad (3)$$

The STATCOM's absorbed

$$\text{Reactive Power} = V_s I_0 \cos\theta_0 \quad (4)$$

For unity power factor operation,

$$V_s I_L \sin\Phi_L = V_s I_0 \cos\theta_0 \quad (5)$$

Once more, the STATCOM system's inverter will generate the output voltage V_0 with the correct magnitude $|V_0|$ and phase θ_0 , which leads to unity power factor operation as the reactive portion of I_0 , $I_0 \cos\theta_0$, balances the reactive component of the load current, $I_L \sin\Phi_L$. The inductive load must have an additional inductive effect applied to it via STATCOM.

IV. DESIGN OF PV-STATCOM

The following elements comprise Photo voltaic – Static Synchronous Compensator model. It consists of a voltage source converter, an inverter circuit and filter circuits.

A. Voltage Source Converter (VSC)

The DC input voltage is changed into an AC output voltage using a voltage-source converter. The following list includes two popular VSC kinds.

B. Square-wave Inverters using Gate Turn-Off Thyristors

Because the output voltage of the converter is proportional in this kind of VSC, the output AC voltage can be changed by adjusting the DC capacitor input voltage.

C. PWM Inverters using Insulated Gate Bipolar Transistors (IGBT)

It converts a DC voltage source using a common chopping rate of a few kHz into a sinusoidal waveform using the pulse width modulation (PWM) approach. The IGBT-based VSC uses a fixed DC voltage compared to the GTO-based kind and modifies the resulting AC voltage by altering the PWM modulator's modulation index.

D. SOLAR FARM

The voltage source converter receives steady 200V DC voltage from a solar farm. Among the output of the VSC and the power system is a transformer. In essence, a transformer serves as a coupling medium. Transformers also eliminate harmonics that are present in the square waves that VSC produces.

E. LCL FILTER

For the purpose of to filter the harmonics generated by the inverter, an LCL filter is frequently employed when connecting an inverter to the utility grid. In spite of abundance of paper available which describes about LCL filters, a systematic process for design hasn't been proposed.

F. APPLICATION OF PV-STATCOM

One of the main issues with power systems is voltage stability. The maximum transfer capacities of the power network can be increased by the series and shunt correction. Regarding voltage stability, this type of compensation aims to inject reactive power to keep the nodes voltage magnitudes close to their nominal values, as well as to decrease line currents and, as a result, the overall system losses decreases. Due to advancements in power electronics, it is now possible to change the magnitude of the voltage at specific system nodes using complex and adaptable devices called FACTS. The static synchronous compensator (STATCOM) is one of them.

V. CONVENTIONAL VOLTAGE INJECTION METHODS

There are many conventional voltage injection methods such as the presage compensation method, Phase advance method, Voltage tolerance method with minimum energy injection, In phase voltage injection method and many more.

A. Pre – sag compensation method

With this technique, the system receives the voltage difference between the sag and pre-fault voltages. The best way to achieve an identical load voltage as the pre-fault voltage is to inject active power without control, hence high capacity energy storage is necessary.

B. Phase advance method

The power angle that exists between sagging voltage and load current is reduced to reduce the real power used by STATCOM. We can only alter the phase of the sag voltage because the load current and voltage values in the system are fixed.

C. Voltage tolerance method with minimum energy injection

The operation characteristics of loads are often unaffected by voltage magnitudes between 90% and 110% of the original voltage and phase angle variations between 5% and 10% of the normal state. With only a slight variation in voltage magnitude, this approach can keep load voltage within the acceptable range.

D. In phase voltage injection method

This is the simple and widely used method, as illustrated in Figure 3, in which the injected STATCOM voltage,

irrespective of the load current and the pre-fault voltage, is in phase with the supply side voltage. There are two distinct approaches to implement this function. The first way involves utilizing a synchronized PLL with the post-fault voltage, while the second involves employing symmetrical components. Despite being a quick control algorithm, the post fault PLL cannot prevent phase leaps on the load voltage at the time of the fault, which can disrupt the transition-angle controlled rectifier loads. The Fortescue transform computation introduces a delay period into the symmetrical components technique, however, and the filter sequence is parameter dependent.

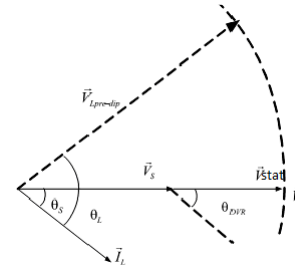

Fig.3. Phasor diagram of IPC Method

Additionally, the pre-fault phase angle can be used by the symmetrical components technique to accommodate the impact caused by a phase jump. The IPC technique can be used for operation strategies requiring low voltage or low energy. In other words, this strategy necessitates a sizable energy storage device in order to offset the voltage sag.

According to Figure 3, the apparent power of STATCOM is

$$S_{STATCOM} = I_L \cdot V_{STATCOM} = I_L (V_L - V_S) \dots \dots \dots (6)$$

And the active power of STATCOM is

$$P_{STATCOM} = I_L V_{STATCOM} \cos \theta_s = I_L (V_L - V_S) \cos \theta_s \dots (7)$$

The magnitude and angle of the STATCOM voltage are

$$V_{STATCOM} = V_S - V_L \dots \dots \dots (8)$$

$$\theta_{statcom} = \theta_s \dots \dots \dots (9)$$

Which are frequently operated in the standby mode or in the injection mode. The low voltage winding of the booster transformer has been shorted across the converter when it is in standby mode ($V_{STATCOM}=0$). In this mode of operation, no semiconductors are switched since each converter leg is activated in a way that creates a short circuit path to the transformer connection.

With the help of the phase loop lock (PLL), the applied voltage and the phase angle are in phase. The voltage sag compensation is therefore accurate and in sync with the supply voltage in this case. As it takes less time to detect the sag, this method is more frequently used in compensation techniques. Hysteresis voltage control and DQ₀ transformation are used in the suggested method to compensate for sag.

VI. CONTROL ALGORITHM

With the help of a DQ₀ Transformation-based control system, the inverter output can be directed in phase with the arriving ac source while the load is kept constant when a voltage disturbance occurs. The output of the inverter is

connected with capacitors and inductors as part of the filtering scheme of the suggested method.

In a STATCOM, the controller's main responsibilities are to identify voltage sag/swell events in the system, calculate the correcting voltage, generate trigger pulses to operate a sinusoidal PWM-based DC-AC inverter, correct any errors in series voltage injection, and identify the trigger pulses after the event has passed. The controller may also be used to turn the DC-AC inverter into rectifying mode so that the capacitors in the DC power connection can be charged when there are no voltage sags or swells.

STATCOM is controlled via the dqo transformation or Park's transformation [6-9]. The phase shift and sag depth information, along with the beginning and ending times, are provided via the dqo method. The immediate space vectors are used to express the quantities. First, change the voltage's reference frame from a-b-c to d-q-o.

Zero phase sequence elements are disregarded for simplicity. A flow chart for the feed-forward dqo conversion for voltage sags/swells detection is shown in Figure 4. Every of the three phases includes the detection. The suggested system's control strategy compares a voltage reference to the measured terminal voltages (Va,Vb,Vc).When the supply voltage falls below 90% of the reference value, voltage sags are recognised, but voltage swells are identified when it rises up to 25% of the reference value. In order to create the commutation pattern of the power switches (IGBTs) that make up the voltage source converter, the error signal is employed as a modulation signal. The conversion from the three phase systems a, b, and c to the dq0 stationary frame is described by equation (5). Phase A of this transformation is in quadrature with the q-axis and is aligned to the d-axis. The angle that exists between phase A and the d-axis that determines what theta (θ) .sinusoidal pulse width modulation technique (SPWM) is used to create the commutation pattern, and the modulation is used to control voltages. Figure 4 depicts the phase locked loop's (PLL) block diagram. To produce a unit sinusoidal wave that is in phase with the mains voltage, the PLL circuit is employed.

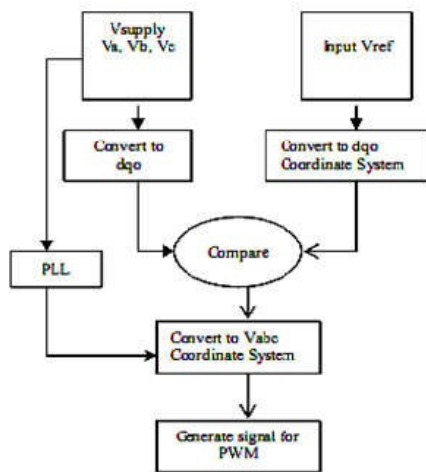

Fig.4. Feed forward control Technique for DQ₀ transformation

The balanced three-phase voltages Va, Vb, and Vc are converted to constant voltages Vd, Vq after conversion. As

seen in Fig. 5 [6], they are simply controlled by PI controller. In order to increase the load voltage and determine the signals that switch for inverter gates, hysteresis voltage control is employed in this paper. A signal of error from an injection voltage and a STATCOM reference voltage that generates appropriate control signals forms the foundation of the hysteresis voltage control. Due to the accurate source phase detection, this method shouldn't be influenced by harmonics, frequency changes, or unbalanced voltages.

$$\begin{bmatrix} Vd \\ Vq \\ V0 \end{bmatrix} = \begin{bmatrix} \cos(\theta) & \cos(\theta - \frac{2\pi}{3}) & 1 \\ -\sin(\theta) & -\sin(\theta - \frac{2\pi}{3}) & 1 \\ \frac{1}{2} & \frac{1}{2} & \frac{1}{2} \end{bmatrix} \begin{bmatrix} Va \\ Vb \\ Vc \end{bmatrix} \quad \dots\dots\dots (10)$$

(a)

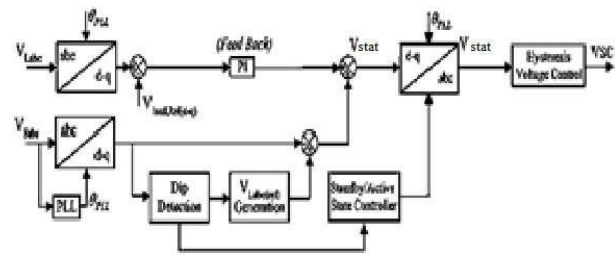

(b)

Fig.5. (a) d-q Transformation (b) Control structure of STATCOM

This condition is satisfied by the phase lock loop. As a result, the corrected voltage and the pre-sag voltage will be in phase. To increase transient stability and, as a result, the power transmission limit, this system presents new voltage control for a grid-connected PV solar farm inverter to function as a STATCOM both at night and during the day. This method of using a PV solar farm as a STATCOM is known as "PVSTATCOM."In contrast to normal solar farm operation, it makes use of the entire solar farm inverter capacity at night and the remaining inverter capacity following the day's actual power generation.

VII. PROPOSED SYSTEM

A. Modes Of Operation Of STATCOM

The proposed system of STATCOM and Photovoltaic system uses three modes of operation . one is the partial STATCOM mode , Full STATCOM mode and full PV mode

B. Partial STATCOM Mode

When the smart inverter uses the remaining inverter capacity following actual power injection, it operates in this mode during the day to exchange reactive power with the grid. In this phase, real power generation takes precedence.

C. Full STATCOM Mode

When there is a significant demand for reactive power supply during disturbances like faults, the Full STATCOM mode is used. In this mode, the smart PV solar system autonomously stops producing real electricity and releases all of its inverter capacity for STATCOM operation for however

long the grid requires. Either the solar panels are disconnected or the voltage across them is raised above the open circuit voltage to stop the actual power generation. This mode is only used when necessary during the day, however it is always available at night because there is no sun. Based on system requirements, the type of transient/disturbance, the time of day, and remaining inverter capacity, the intelligent PV inverter autonomously chooses among active power generation and reactive power exchange.

D. Full PV Mode

The solar system provides just real power in this daylight mode, with no support from reactive power. The DC link capacitor supplies actual power to make up for the inverter IGBT switches' power loss. As a result, the DC link capacitor voltage steadily decreases. To maintain the DC link capacitor charged, a limited amount of active power must be absorbed by the inverter. The smart inverter control uses just a small portion of dc power from the solar panels when there is sunlight to keep the capacitor charged while injecting the majority of the solar energy into the grid.

The capacitor is charged at night by the inverter control using just a small quantity of actual electricity from the grid and inverter diodes. The DC link voltage control utilizing PI controller's open loop transfer function. Reactive power that is readily available for voltage management during periods of strong solar power output is a constraint of smart inverters. Due to significant disturbances happening around midday, they are incapable to provide voltage management during significant drops in grid voltage. Utilizing voltage and current controllers along with optimization techniques, the existing circuit is modified.

The benefits of optimized PV-STATCOM include using lower VSI ratings, operating at a lower dc link voltage, achieving the global optimum more quickly, improving compensating, and maintaining constant performance under varying loads. The controller and filter settings of PV-STATCOM can be tuned when higher voltage conditions and other changes to the system occur.

This optimization technique just needs the common control parameters to progress towards the optimum solution while avoiding the worst. The system is made up of a STATCOM setup and a PV solar farm that is connected to the grid on the distribution side. Both linear and nonlinear loads connect the grid. The new, improved control method with the voltage and current controllers received the control signals. The error signals were converted into a gating pulse to create the three-phase voltage needed to inject a compensatory voltage into the grid.

E. System Details

PV Solar Farm

Voltage Produced = 200V
Current Produced = 14.25A

Distribution Grid

Voltage V_{rms} in normal condition = 415V
Current I_{abc} in normal condition = 10A

LCL Circuit

Inductance rating = $150e^{-3}H$
Capacitance rating = $120e^{-6}F$

Non Linear Load rating

Resistance rating = 45 ohm
Inductance value = $20e^{-3}H$
Linear Load rating = 1 KW
Power rating = 1 KW

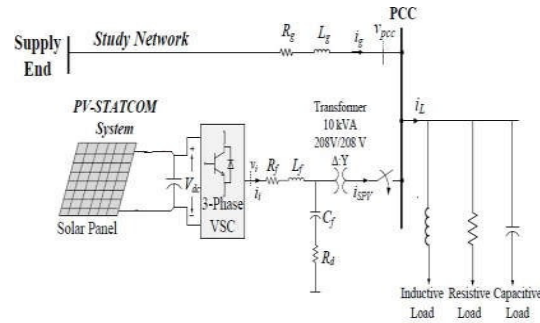

Fig.6. Proposed system model

MATLAB SIMULINK was used to estimate the control strategy efficiency. The aforementioned data are the input system's parameters and constants values.

The solar system provides just real power in this daylight mode, with no support from reactive power. The DC link capacitor supplies actual power to make up for the inverter IGBT switches' power loss. As a result, the DC link capacitor voltage steadily decreases. To maintain the DC link capacitor charged, a limited amount of active power must be absorbed by the inverter. The smart inverter control uses just a small portion of dc power from the solar panels when there is sunlight to keep the capacitor charged while injecting the majority of the solar energy into the grid

VIII. SIMULATION RESULTS AND DISCUSSION

A. Phase To Phase Voltage

The simulation graph below demonstrates the variations in the electrical system's phase-to-phase voltage that took place at 0.15 seconds after a nonlinear load was connected to the distribution system. This sag continued for 0.25 seconds. As indicated in the picture below, the system is stabilized at this precise moment by the injection of the compensating voltage. In order to correct the voltage drop in the distribution system, the control loop detects variations in the intended grid voltage and sends an error signal to the PWM, which in turn activates the VSI in the STATCOM.

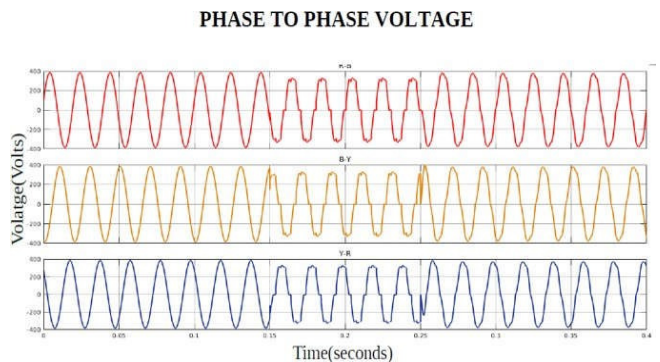

Fig.7. Phase to phase sag voltage

B. Load Voltage

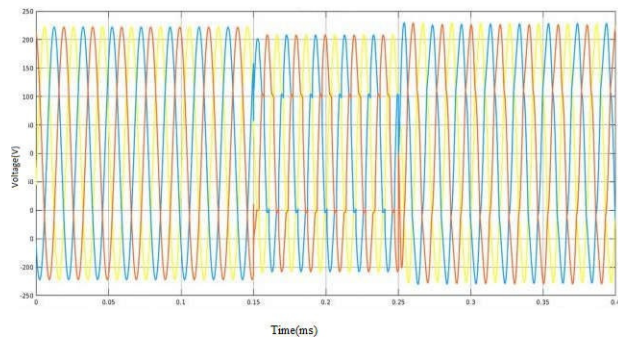

Fig.6. Load voltage with sag

Fig.6 shows the simulated value which depicts the changes in load voltage brought on by the system sag. The sag is corrected by introducing voltage into the network after 0.25 seconds.

C. Load current

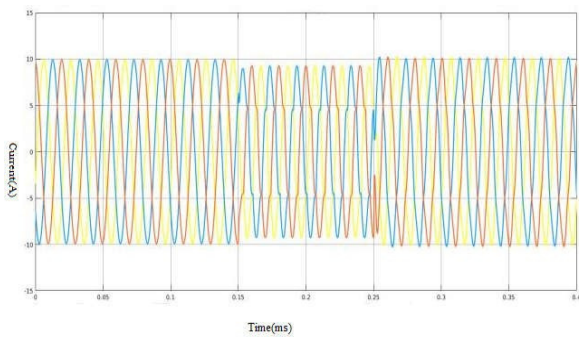

Fig.7. Load current with sag

Likewise Load In the fig.7, current variations was displayed. The sag is corrected after 0.25 seconds by adding voltage to the system.

D. Sag Compensation

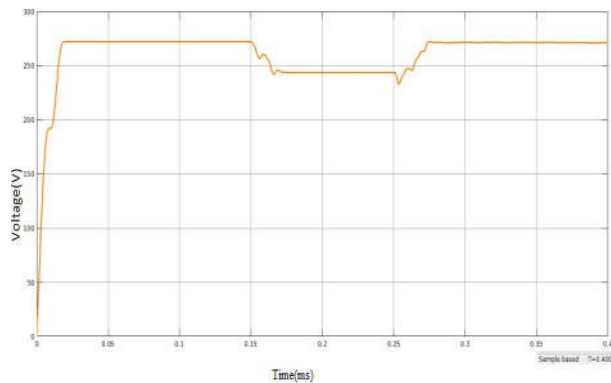

Fig.7. Sag compensation

The RMS value, which was computed using the single-phase distribution system voltage and plotted, is shown in the number above. The sag appears here between 0.15 and 0.25 seconds.

E. Compensation Voltage From The PV-STATCOM

The compensating voltage created by the VSI of STATCOM after it has been set through an LCL filter is represented by the waveforms below. These voltage indications were useful in reversing the distribution system's voltage decline. The load voltage after compensation is shown in above figure where the sag is appearing between 0.15 and 0.25 seconds and after being compensated is shown below in Fig.8

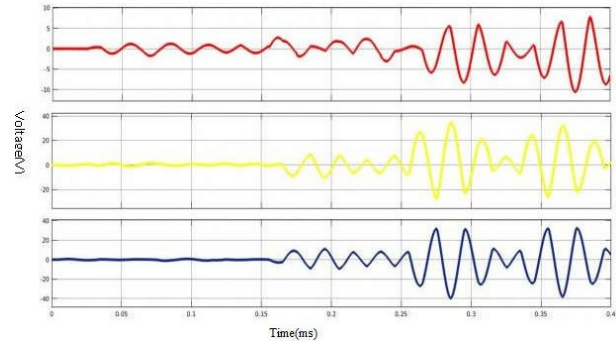

Fig.8.Compensated Load voltage from PV-STATCOM

The compensating voltage created by the VSI of STATCOM after it has been set through an LCL filter is represented by the waveforms above. These voltage indications were useful in reversing the distribution system's voltage decline.

F. Total Harmonic Distortion After Compensation

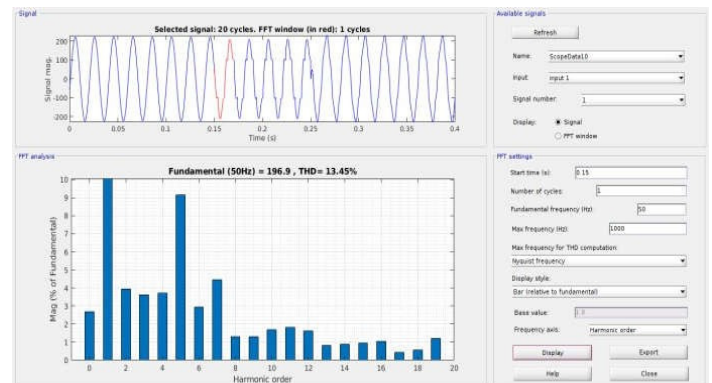

Fig.8.Total harmonic distortion of the compensated voltage

The accompanying figure displays the FFT analysis of the voltage signal. Here, the fundamentals' harmonic order versus mag% was displayed, as seen in the bar graph. In order to determine the system's total harmonic distortion, one cycle time period is taken into account. In the system, 13.45% of THD is visible above.

IX. CONCLUSION

The significance of power quality plays a very major role in maintaining the grid discipline and power factor. The STATCOM-PV system solves the voltage mitigation problem in the power system effectively. Here with the PV-STATCOM a power system model is designed using MATLAB simulink and sag is created for duration of 10ms

and the sag is being compensated effectively using the proposed system.

REFERENCES

- [1] Aysenur Oymak, Mehmet Rida Tür, Ekşas Hossain, "Modeling of STATCOM Connected System to Microgrid", *2022 Global Energy Conference (GEC)*, pp.202-207, 2022
- [2] K. Santhosh, Kalagotla Chenchireddy, Pulluri Vaishnavi, A. Greeshmanth, V. Mahesh Kumar, Police Nandakishore Reddy, "Time-Domain Control Algorithms of DSTATCOM in a 3-Phase, 3-Wire Distribution System", *2023 International Conference on Intelligent Data Communication Technologies and Internet of Things (IDCIoT)*, pp.781-785, 2023.
- [3] V. Kumar, Kalagotla Chenchireddy, Khammapi R Sreejyothi, Thumuluri Usha, Ankireddy Venkatasaireddy, Bandari Rakesh, "Distribution System Power Quality Improvement using IRP Theory", *2023 7th International Conference on Computing Methodologies and Communication (ICCMC)*, pp.1450-1454, 2023.
- [4] Chang S., HoY.S., and Loh P.C.: Voltage quality enhancement with power electronics based devices. In *IEEE Power Engineering Society Winter Meeting*, 2000, pp. 2937–2942.
- [5] Kim H.: Minimal Energy Control for a Dynamic Voltage Restorer. In *Proceedings of the Power Conversion Conference, Osaka, Japan, 2002*, pp. 428–433.
- [6] McHattie R.: Dynamic Voltage Restorer the Customer's Perspective. In *IEE Colloquium on Dynamic Voltage Restorer—Replacing Those Missing Cycles*, 1998, pp. 1/1–1/5.
- [7] Chen S., Joos G., Lopes L., and Guo W.: A nonlinear control method of dynamic voltage restorers. In *2002 IEEE 33rd Annual Power Electronics Specialists Conference*, 2002, pp. 88–93.
- [8] Buxton R. Protection from voltage dips with the dynamic voltage restorer. In *IEE Half Day Colloquium on Dynamic Voltage Restorers—Replacing Those Missing Cycles*, 1998, pp. 3/1–3/6.
- [9] Li B.H., Choi S.S., and Vilathgamuwa D.M.: 12. Design considerations on the line-side filter used in the dynamic voltage restorer. *IEE Proceedings — Generation, Transmission, and Distribution*, vol. 148, pp. 1–7, Jan.2001.
- [10] Chan K.: Technical and Performance Aspects of a Dynamic Voltage Restorer. In *IEE Half Day Colloquium on Dynamic Voltage Restorers—Replacing Those Missing Cycles*, 1998, pp. 5/1–5/25.
- [11] P. T.Nguyen.,Tapan.,and K.Saha.: "Dynamic Voltage Restorer Against Balanced and Unbalanced Voltage Sags: Modeling and Simulation *IEEE* 2004, pp.1-6.
- [12] V.K.Ramachandaramurthy, A.Arulampalam, C.Fitzer, C. Zhan, M. Barnes and N. Jenkins "Supervisory control of dynamic voltage restorers " *IEE Proc.- Gener. Transm. Distrib.* Vol. 151, No. 4, pp. 509-516, July 2004
- [13] John Godsk Nielsen, Michael Newman, Hans Nielsen, Frede Blaabjerg, "Control and Testing of a Dynamic Voltage Restorer (DVR) at Medium Voltage Level" *IEEE Transactions on Power Delivery*, Vol. 19, No. 3, MAY 2004
- [14] Sng E.K.K., Choi S.S., and Vilatgamuwa DM.: Analysis of Series Compensation and DC-Link Voltage Controls of a Transformerless Self-Charging Dynamic Voltage Restorer. *IEEE Transactions on Power Delivery*, vol. 19, pp. 1511–1518, July 2004.
- [15] Bollen M.H.J.: *Understanding Power Quality Problems*. NewYork: IEEE Press, 2000.
- [16] E -Otaoui a , Viscarreti s U .,Bacha S . , Caballero M., a n d Reyero R. : Evaluation of different strategies for series voltage sag compensation. In *Proc. 2002 IEEE-PESC*, vol. 4, pp. 1797–1802.
- [17] ChungY. , Park S . -Y. , Moon S . - I . , a n d Hu r S . - I . :The control and analysis of zero sequence components in DVR system. In *Proc. 2001 IEEE-PES Winter Meeting*, Vol. 3, pp. 1021–1026.
- [18] Haddad K. a n d Joos G. : Distribution system voltage regulation under fault conditions using static series regulators. In *Proc. 1997 IEEE-IAS*, Vol. 2, pp. 1383–1389.
- [19] Joos Camp o s G. , Ziogas P, a n d Lindsay J .: Analysis and design of a series voltage compensator for three-phase unbalanced sources. *IEEE Trans. on Industrial Electronics*, Vol. 39, No. 2, pp. 159–167, April 1992.
- [20] Tounsi R, Michalak P. ,Pouliquen H. , a n d Foch H.: Series compensator voltage dips: control strategy. In *Proc. 1997 EPE Con.*, pp. 4.929–4.934.
- [21] Sannino a n d Svensson J . : A series-connected voltage source converter for voltage sag mitigation using vector control and a filter compensation algorithm. In *Proc. 2000 IEEE-IAS*, Vol. 4, pp. 2476–2481