

## DESIGN OF FOOT OVER BRIDGE WITH THE VARIATION OF STIFFNESS TO WEIGHT RATIO WITH THE HELP OF TOPOLOGY OPTIMIZATION

K. HEMALATHA<sup>1</sup>, K. SAITEJA<sup>2</sup>, MD. MAHBOOBURRAHMAN

<sup>3</sup>, S. VIJAYKUMAR<sup>4</sup>, T. ANKITHSINGH<sup>5</sup>

<sup>1</sup>Assistant Professor, Dept. of Mechanical Engineering, St. Martin's Engineering College,

<sup>2,3,4</sup>Students, Dept. of Mechanical Engineering, St. Martin's Engineering College

### ABSTRACT

Footbridges are needed where there is a separate pathway must be supplied for human beings to move site visitors flows or some physical impediment, along with a river. The masses they convey are, with regard to toll road or railway bridges, pretty modest, and in most circumstances a reasonably light structure is needed. They are, but, often required to give a protracted clear span, and stiffness then becomes a crucial consideration. The bridges are frequently required very virtually on view to the general public and consequently the advent deserves careful attention. Steel offers financial and appealing kinds of creation which suit all of the requirements demanded of a footbridge.

### INTRODUCTION

A footbridge (also a pedestrian bridge, pedestrian overpass, or pedestrian overcrossing) is a bridge designed solely for pedestrians.<sup>[1]</sup> While the primary meaning for a bridge is a structure which links "two points at a height above the ground", a footbridge can also be a lower structure, such as a boardwalk, that enables pedestrians to cross wet, fragile, or marshy land.<sup>[2]</sup> Bridges range from stepping stones – possibly the earliest man-made structure to "bridge" water – to elaborate steel structures. Another early bridge would have been simply a fallen tree. In some cases a footbridge can be both functional and artistic.

### TYPES OF FOOT OVER BRIDGES

Types of footbridges include but are not limited to:

- Beam Bridge
- Boardwalk
- Clapper bridge
- Plank road
- Corduroy road
- Moon bridge
- Simple suspension bridge
- Living bridge
- Simple truss

**PROJECT DESIGN**

CATIA (Computer Aided Three-dimensional Interactive Application) is a multi-platform CAD/CAM/CAE commercial software suite developed by the French company Dassault Systems. Written in the C++ programming language, CATIA is the cornerstone of the Dassault Systems product lifecycle management software suite.

CATIA competes in the CAD/CAM/CAE market with Siemens NX, Pro/E, Autodesk Inventor, and Solid Edge as well as many others.

Developer(s)	Dassault Systems
Stable release	V6R2011x/November 23, 2010
Operating system	Unix/Windows
Type	CAD software
License	Proprietary
Website	WWW.3ds.com

**MEASUREMENTS:**

MEASUREMENTS	VALUES
Length	30m
Width	5m
Height	3m
Thickness	0.3m
Force	41678N

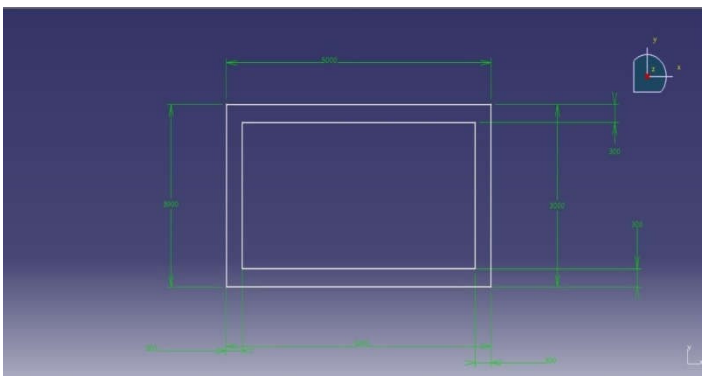
**DESIGN:**

**Pad(extrude):Pocket(hole):**

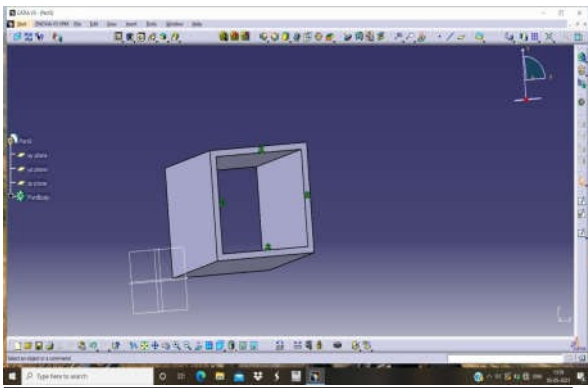
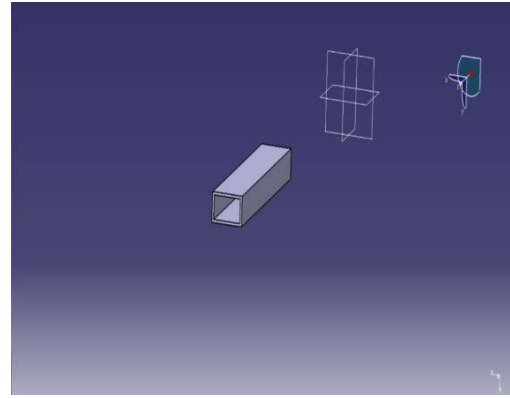
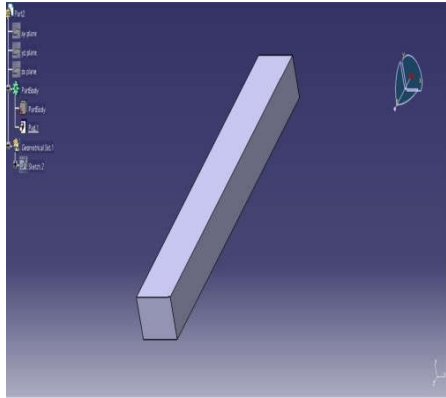



## PROJECT IMPLEMENTATION

### ANALYSING EXPERIMENTAL DATA:

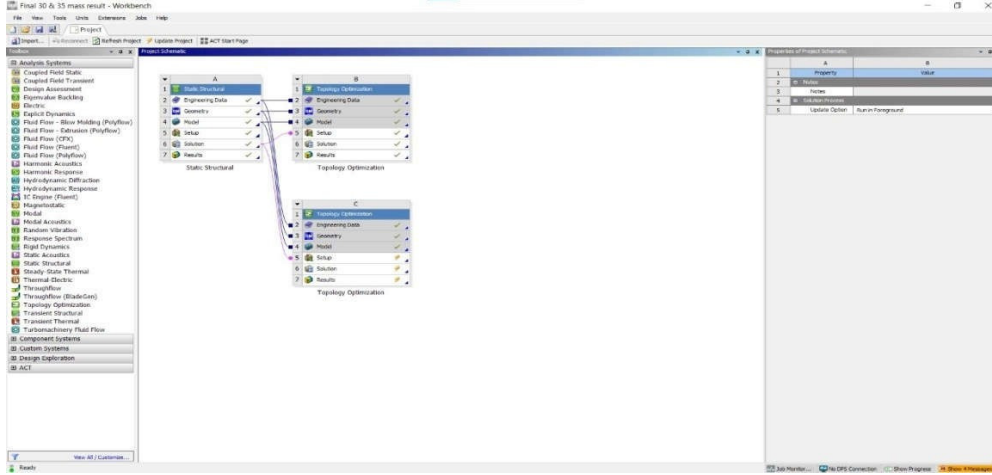

### MESH:

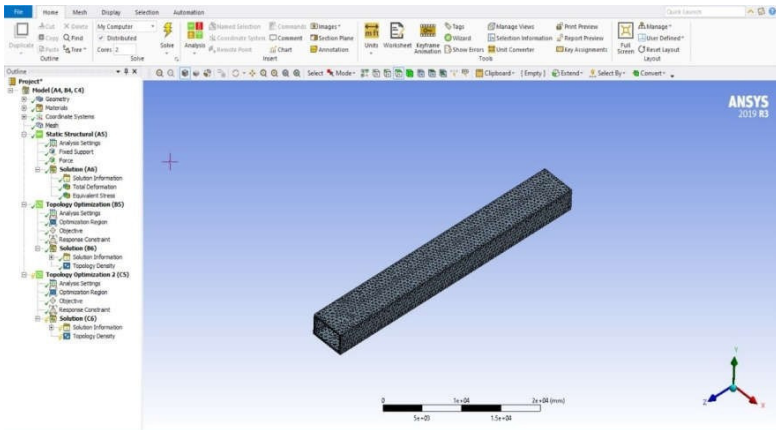

### FIXEDSUPPORT:

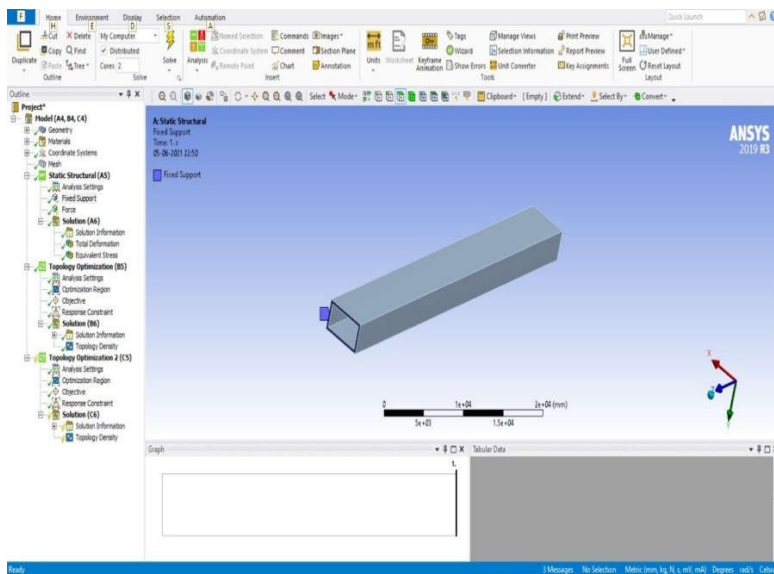

**LOADACTING:**

Average weightxNo.of peoplexGravitational force=

$$\text{Force(Load)} 85\text{kgs} \times 50 \times 9.81 = 41678\text{N}$$

Force(Load)=Deformation41678

$$\text{N} = 0.0085297\text{ra}$$

**FORCE:**

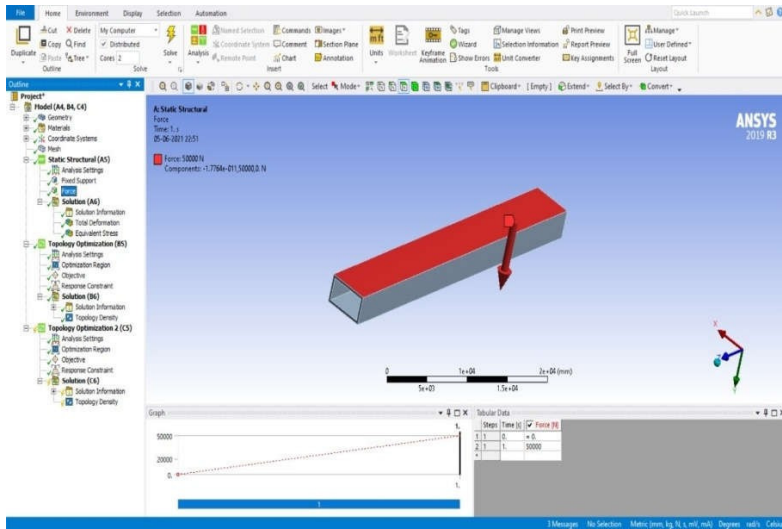

**EQUIVALENTSTRESS:**

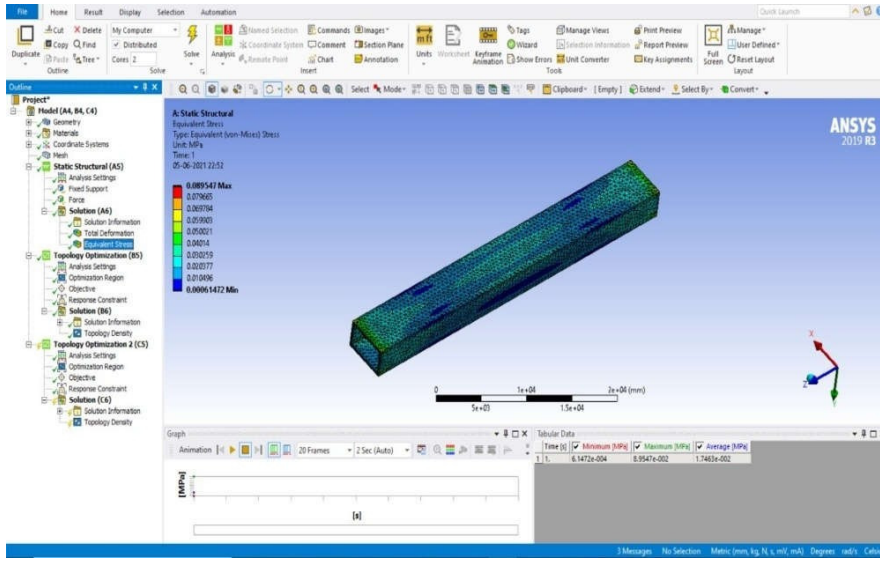

**TOTALDEFORMATION:**

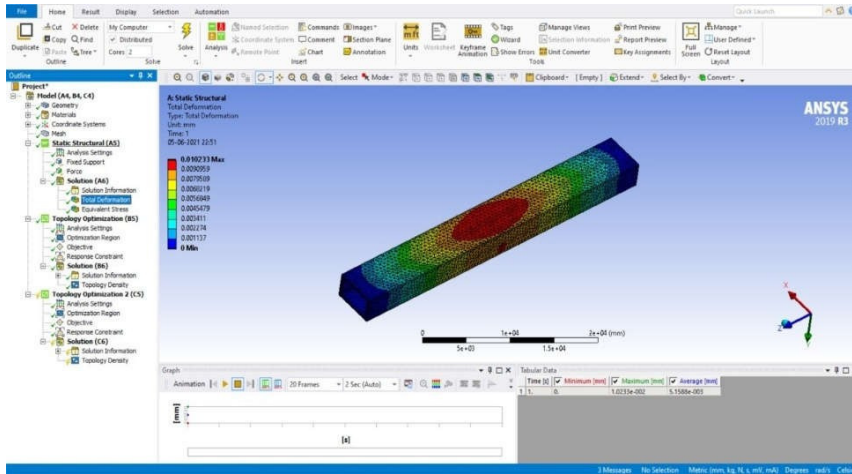

**DEFORMATIONSAMPLES:**

LOAD	DEFORMATION
40000N	0.0081863
42000N	0.0085956
44000N	0.0090049
46000N	0.0094143



48000N	0.0098236
50000N	0.010233

### TOPOLOGYOPTIMIZATION:

The study of topology optimization is making a difference in weight (mass) without any change in dimensions.

Removal of excess material where there is no stress acts on it, it is also called topology optimization. It is also used to reduce the weight (mass) in case of getting good performance.

### OPTIMIZATIONREGION:

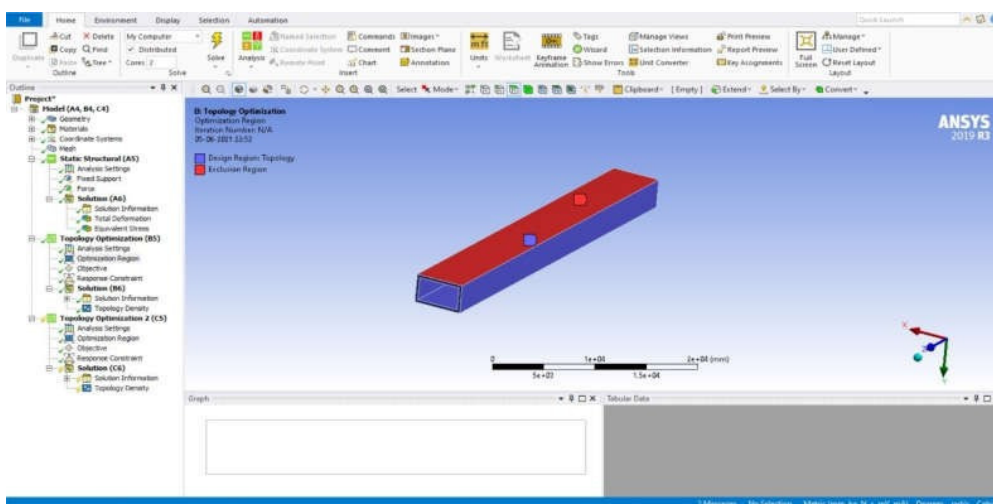

**RESPONSECONSTRAINT:**

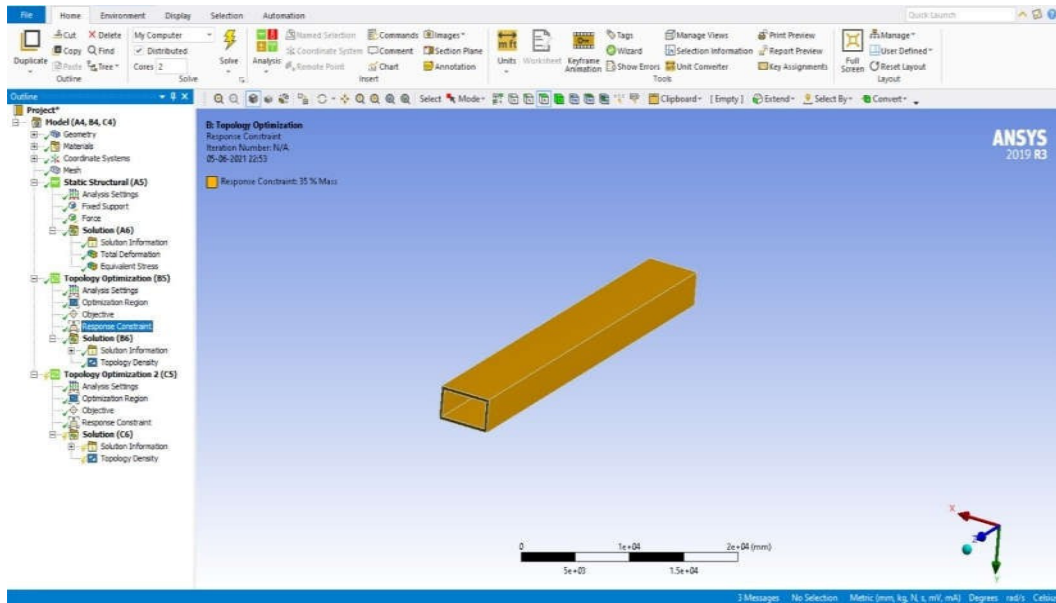

**TOPOLOGYOPTIMIZATIONRESULT:**

S.NO	MATERIAL	DENSITY	RESPONSECONSTRAINT	ORIGINAL MASS	MASS AFTER TOPOLOGYOPTIMIZATION	PERCENTAGE OF MASS REDUCED
1.	Structural steel	8654.9kg	30%	1537.15kg	868.88kg	43.408%
2.	Structural steel	8654.9kg	35%	1537.15kg	919.06kg	40.208%

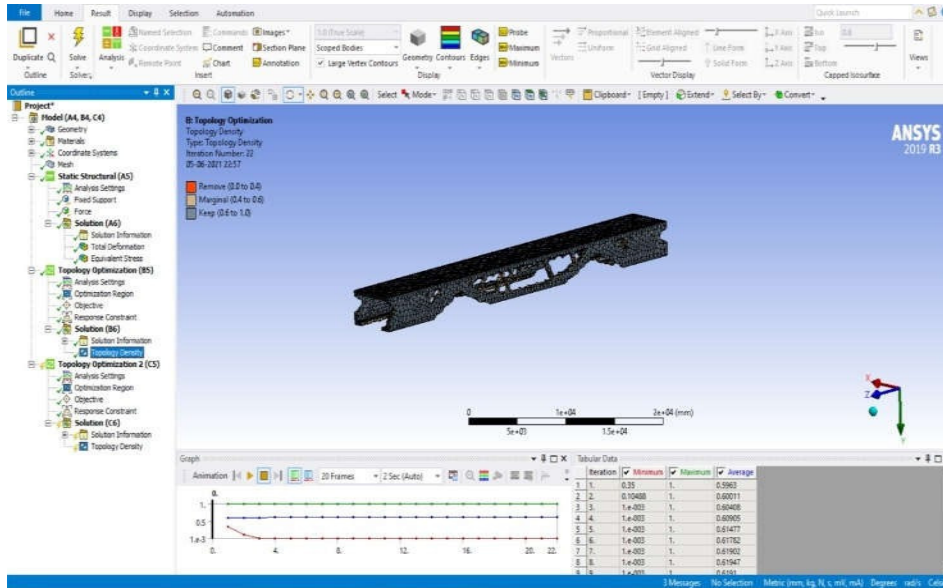
**ANALYSING EXPERIMENTAL RESULT (FINAL RESULT):****CONCLUSION**

In this project we did design of a foot over bridge by using CATIA-V5-R2011. After the completion of design, we did analysis by using ANSYS Workbench with help of Topology optimization. We got a good performance of the foot over bridge by giving the measurements which we used in this Project and we also did the variation of Stiffness to Weight (mass) ratio. As a future scope of study, manufacturing techniques for Foot over Bridge could be used in all the heavy traffic routes, and also be able to construct strong enough to withstand.

**REFERENCES:**

- 1) Gimsing N.J. (1997) Cable Supported Bridges Concept & Design, 2nd edn. Wiley, Chichester.
- 2) Podolny W., Jr. and Scalzi J.B. (1986) Construction and Design of Cable Stayed Bridges, 2nd edn. Wiley, New York, USA.
- 3) Troitsky M.S. (1988) Cable-stayed Bridges, 2nd edn. BSP, Oxford.
- 4) Walther R., Houriet B., Walmar I. and Mor'a P. (1988) Cable Stayed Bridges. Thomas Telford, London.
- 5) Fischer G. (1960) The Severin Bridge at Cologne (Germany). Acier-Stahl-Steel, No. 3, 97-107.
- 6) Leonhardt F. and Zellner W. (1980) Cable-stayed bridges. International Association for Bridge and Structural Engineering Surveys, S-13/80, in LABSE Periodica 2/1980.
- 7) Wenk H. The Stromsmund Bridge. (1954) Stahlbau, 23, No. 4, 73-76.
- 8) D.J. Farquhar Mott Macdonald Cable Stayed Bridges.
- 9) N. Krishna Raju, Design of Bridges.

